



# UPGRADES CATALOG

UPDATED 2021

Availability of upgrades may vary by location and are subject to change. See Tuff Shed online configurator for placement rules.





# FLOOR & PORCH

---

## Treated Floor Decking

**Features** LP® ¾" Thick Treated ProStruct™ Floor Decking with SmartFinish™ Technology.

**Benefits** Treated to resist damage from moisture and insects. Spills on this surface wipe up more easily.

**Availability** Standard on Premier Series® and Premier PRO Series™ sheds. Offered as an upgrade to Garden Series® sheds.

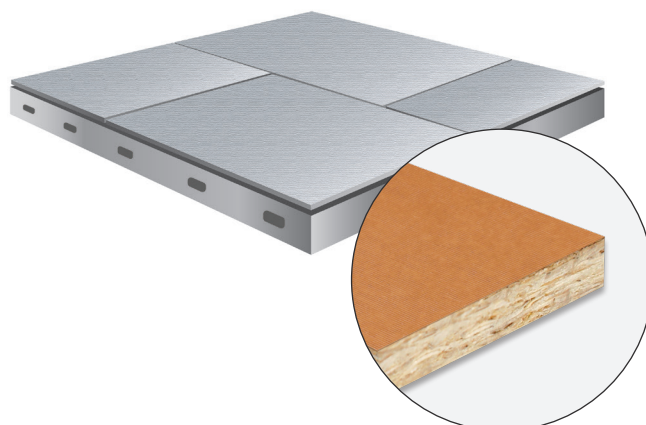

## Double Layer Floor

**Features** Adds another layer of floor decking to sheds. Top layer is LP® ¾" Treated ProStruct™ Floor Decking with SmartFinish™ Technology.

**Benefits** Floor supports heavier weight load.

**Availability** Offered as an upgrade to all sheds. Pair with Joist Spacing Upgrade (sold separately) to maximize floor strength.

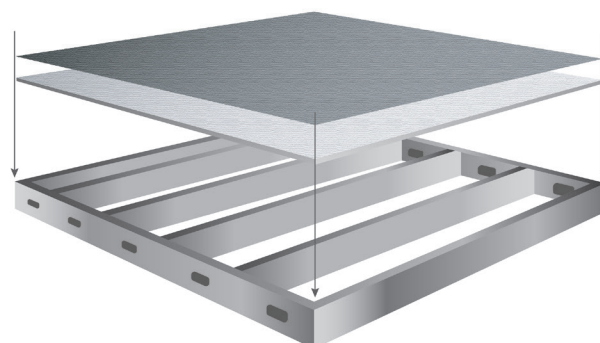

## PT Wood to Steel Joist Upgrade

**Features** Upgrade floor joists from 2x6 Pressure Treated Wood to 2x6 hot-dipped Galvanized Steel.

**Benefits** Won't rot or wick moisture from ground into floor decking.

**Availability** Offered as an upgrade to Garden Series® sheds, except when purchasing building via Rent to Own program. Some 16' Wide Premier Series® and Premier PRO Series™ sheds require PT Wood Floor Joists and may not be upgraded to steel joists.

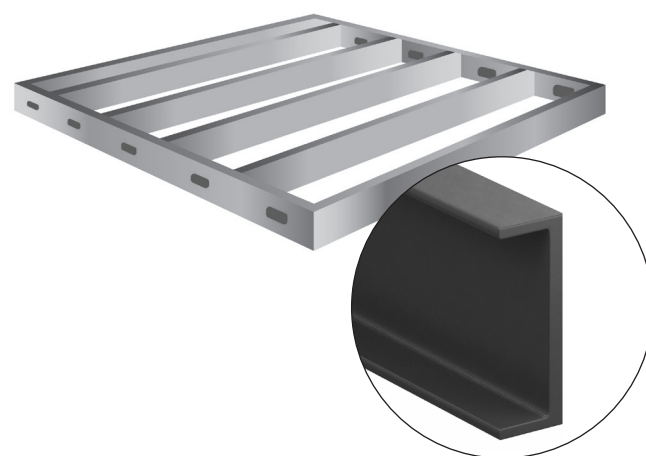

---

## Floor Joist Spacing Upgrade

**Features** Additional floor joists, spaced closer than the standard 24" on center.

**Benefits** Increased floor weight load. Excellent for supporting heavier weight items such as work out equipment, wood shop tools, etc.

**Availability** Offered as an upgrade on PT Wood Floor Joists and Galvanized Steel Floor Joists. Select 12" OC or 16" OC Floor Joist Spacing Upgrade. Pair with Double Layer Floor Upgrade (sold separately) to maximize floor strength.

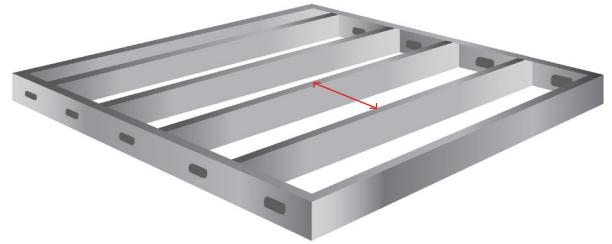



---

## Floor Track Vent

**Features** Small snap-in-place vents for buildings with galvanized steel floor joists. Fits securely into open ventilation holes in joists.

**Benefits** Restricts under floor access for pests.

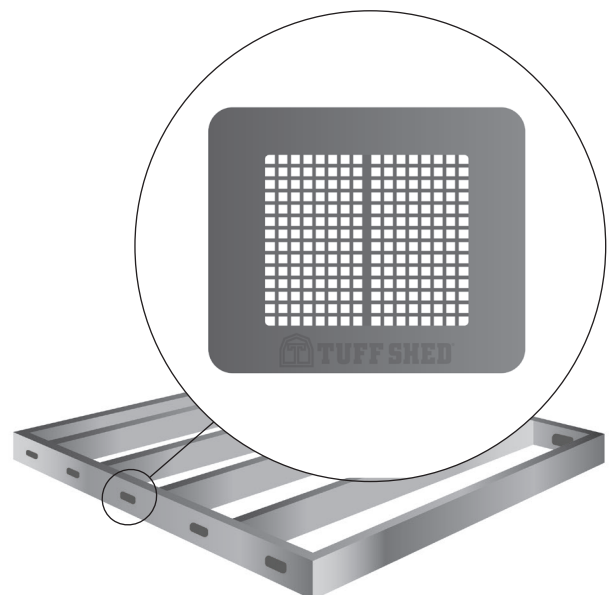
**Availability** Offered as an upgrade to all buildings with galvanized steel floor joist system. One vent per foot of building length (i.e. 10x12 building = 12 Floor Track Vents). Most effective as pest barrier when floor joists have full contact with ground (i.e. no gaps due to leveling blocks).



---

## No Floor Option

**Features** Floor joists and floor decking are removed. Upgraded Pressure Treated wall bottom plates are directly anchored to the customer-supplied concrete pad (PT bottom plates and anchors included).

**Benefits** Increases floor weight load, eliminates potential air gaps under the building and allows for different customer-supplied floor finishes (i.e. tile, wood plank, etc.).

**Availability** Standard on garages and offered as an upgrade on all sheds. Concrete Pad must be square and within 1/2" of prescribed measurement. If building size is larger than 120 square feet, the concrete pad must be engineered.



---

## Porch Decking

**Features** Upgrade Pressure Treated Lumber Decking to Premium Wood Variety or Composite Decking.

**Benefits** Improved performance, durability, and appearance.

**Availability** Offered as an upgrade to buildings with standard porches (i.e. PRO Weekenders). Wood Variety and Composite material will vary by market.

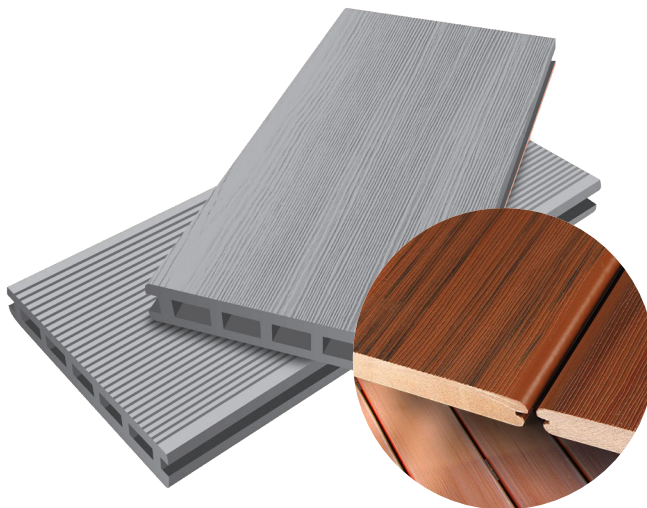

---

## Porch Railing

**Features** Railing and spindles on front and side of porch areas.

**Benefits** Curb appeal and safety.

**Availability** Offered as an upgrade to Premier PRO Series™ Ranch Weekender and Premier PRO Series™ Barn Weekender.





---

## 6' Deep Endwall Porch

**Features** 6' Deep endwall porch. Upgrade from 4' Deep endwall porch.

**Benefits** Additional 2 feet of depth on integrated, front porch.

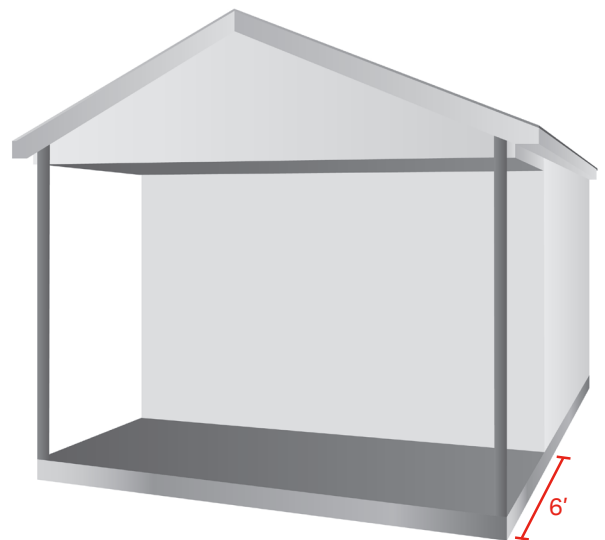
**Availability** Available on Premier PRO Series™ Ranch Weekender and Premier PRO Series™ Barn Weekender. 4' Deep endwall porch is standard on these two models.



---

## Flag Anchor

**Features** Steel anchor affixes shed directly into ground.

---

**Benefits** Secures building in place. Generally selected by customers wanting peace of mind with a basic building anchoring system.

---

**Availability** Specific anchor type varies by building model, market requirements and installation surface.

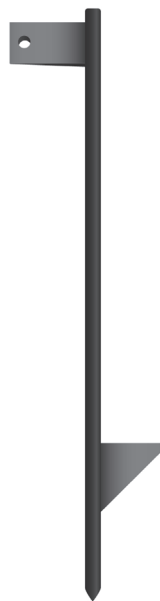

---

## Auger Anchor

**Features** Steel, turn-screw design that is driven into the ground.

---

**Benefits** Secures building in place. Generally selected due to local building requirements.

---

**Availability** Specific anchor type varies by building model, market requirements and installation surface.





# SHED DOORS & ACCESSORIES

---



---

## 4' Wide x 6'2" Tall Shed Door

**Features** Steel reinforced, patented design with one of a kind, heavy-duty hardware and locking handle. Standard on Garden Series®, Premier Series® Ranch and Premier PRO Series™ Ranch buildings.

**Benefits** Will not twist, warp, or sag. Locks securely.

**Availability** Single 6'2" Tall door is standard on Garden Series®, Premier Series® Ranch and Premier PRO Series™ Ranch buildings.

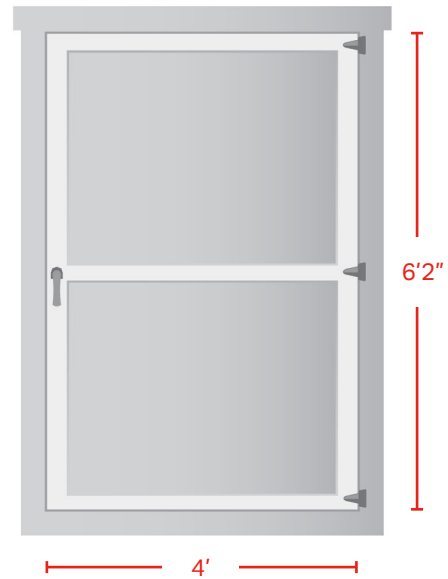

---

## 4' Wide x 6'7" Tall Shed Door

**Features** Taller, steel reinforced, patented design with one of a kind, heavy-duty hardware and locking handle.

**Benefits** Taller door opening. Will not twist, warp, or sag. Locks securely.

**Availability** Single 6'7" Tall door is standard on Premier Series® Tall Ranch and Tall Barn (when placed on end wall), and Premier PRO Series™ Tall Ranch and Tall Barn buildings.

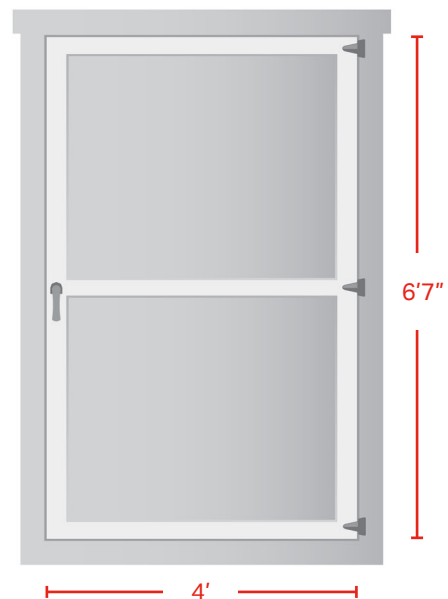

## 6' Wide Double Shed Door

**Features** Two, 3' wide doors. One door includes hardware at floor and top door jamb for securing the door shut. The other door includes same patented, lockable door handle standard on single shed door. Both doors include three heavy duty hinges.

**Benefits** 6' wide total door opening allows easier access for larger items. Doors will not twist, warp, or sag. Locks securely.

**Availability** Offered as an upgrade to most sheds and available in 6'2" and 6'7" heights depending on building model. Height follows same logic as standard shed door on building.

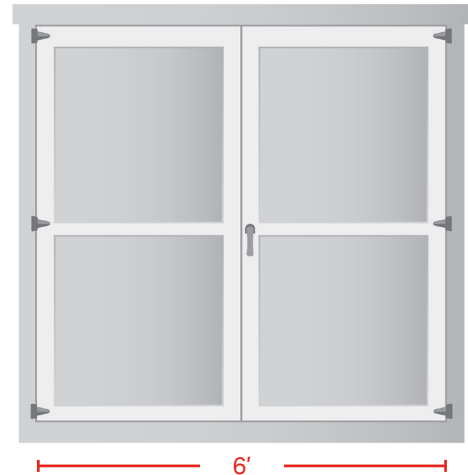

## 8' Wide Double Shed Door

**Features** Two, 4' wide doors. One door includes hardware at floor and top door jamb for securing the door shut. The other door includes same patented, lockable door handle standard on single shed door. Both doors include three heavy duty hinges.

**Benefits** 8' wide total door opening allows easier access for larger items. Doors will not twist, warp, or sag. Locks securely.

**Availability** Offered as an upgrade to most sheds and available in 6'2" and 6'7" heights depending on building model. Height follows same logic as standard shed door on building.



---

## 4'x7' Roll Up Cannister Door

**Features** 4' wide roll up, overhead door. Rolls up inside the building, at the door header. Includes handle and rope, and latch for customer to add lock if desired.

**Benefits** Door can remain in open position for easier loading/unloading building. Overhead door may be preferable to some customers or in some situations (i.e. small installation area). Please note that this type of door is more susceptible to leaking.

**Availability** Offered as an upgrade to Premier Series® and Premier PRO Series™ Tall Ranch and Tall Barn models.



Opening height varies by building style and door placement (6'6" - 7')

---

## 6'x7' Roll Up Cannister Door

**Features** 6' wide roll up, overhead door. Rolls up inside the building, at the door header. Includes handle and rope, and latch for customer to add lock if desired.

**Benefits** Wider version of overhead roll up door allows easier access for larger items. Can remain in open position for easier loading/unloading building. Overhead door may be preferable to some customers or in some situations (i.e. small installation area). Please note that this type of door is more susceptible to leaking.

**Availability** Offered as an upgrade to Premier Series® and Premier PRO Series™ Tall Ranch and Tall Barn models.



---

## Dutch Door Upgrade

**Features** Separate operable door halves with upper and lower section. Two patented, heavy duty hinges on each section. Patented, lockable door handle standard on lower door section. Upper door section includes interior hardware allowing upper section to be fixed to lower section.

**Benefits** Upper and lower door sections can move separately or in conjunction with each other.

**Availability** Offered as an upgrade to most sheds and available in 6'2" and 6'7" heights depending on building model. Height follows same logic as standard shed door on building.





---

## Lower Diamond Trim Upgrade

**Features** Decorative trim in lower half of shed door, angled at each corner. Painted the same color as trim on rest of building.

**Benefits** Curb appeal.

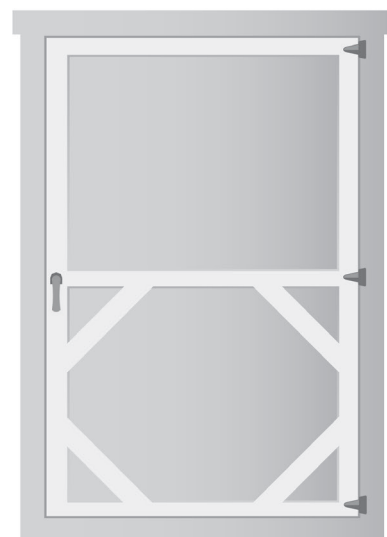
**Availability** Offered as an upgrade to all single and double shed doors.



---

## Wainscott Trim Upgrade

**Features** Decorative trim in lower half of shed door with three vertical pieces. Painted the same color as trim on rest of building.

---

**Benefits** Curb appeal.

---

**Availability** Offered as an upgrade to all single and double shed doors.

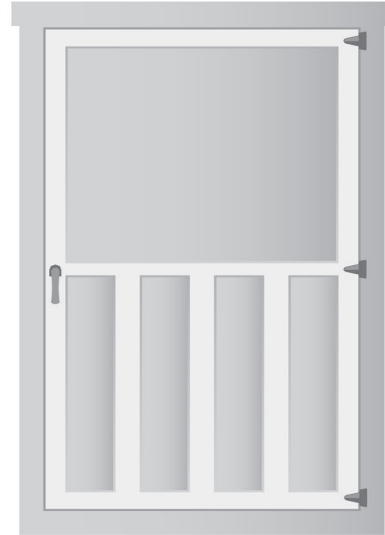

---

## Lower X Trim Upgrade

**Features** Decorative trim in lower half of shed door in shape of an X. Painted the same color as trim on rest of building.

---

**Benefits** Curb appeal.

---

**Availability** Offered as an upgrade to all single and double shed doors.

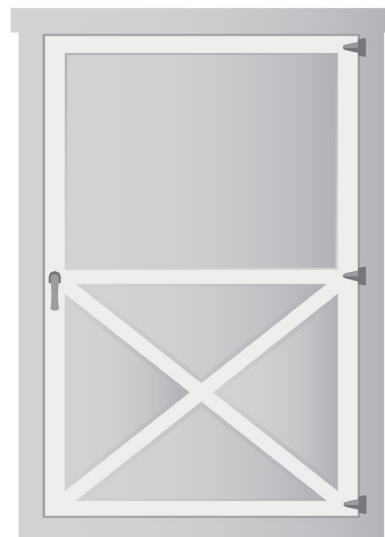

---

## In-Door Horizontal Transom Window

- Features** Stationary, tempered glass transom window in the upper half of the shed door.
- 29" wide x 8" tall window on 3' wide shed door.
  - 41" wide x 8" tall window on 4' wide shed door.

**Benefits** Bring outside light inside the building without sacrificing security.

**Availability** Offered as an upgrade to all single and double shed doors.





---

## In-Door Vertical Transom Window

- Features** Stationary, tempered glass transom windows in the upper half of the shed door.
- Three 8" wide x 16" tall windows on 3' wide shed door.
  - Four 8" wide x 16" tall windows on 4' wide shed door.

**Benefits** Bring outside light inside the building without sacrificing security.

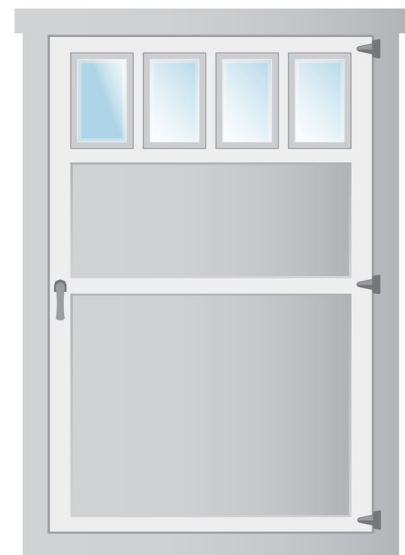
**Availability** Offered as an upgrade to all single and double shed doors.



---

## Black Door Hardware

**Features** Replaces standard, silver shed door hinges and handle. Interior door hardware unaffected.

**Benefits** Exterior curb appeal plus same great performance as standard, silver shed door hardware.

**Availability** Offered as an upgrade to all single and double shed doors.



---

## Security Package

**Features** Door hasp to accommodate customer padlock. Carriage Bolt on top and bottom hinges

**Benefits** Additional security. Locked door cannot be removed from outside by unfastening hinges. Additional lock can be added by customer

**Availability** Offered as an upgrade to all single and double shed doors. Available only in silver

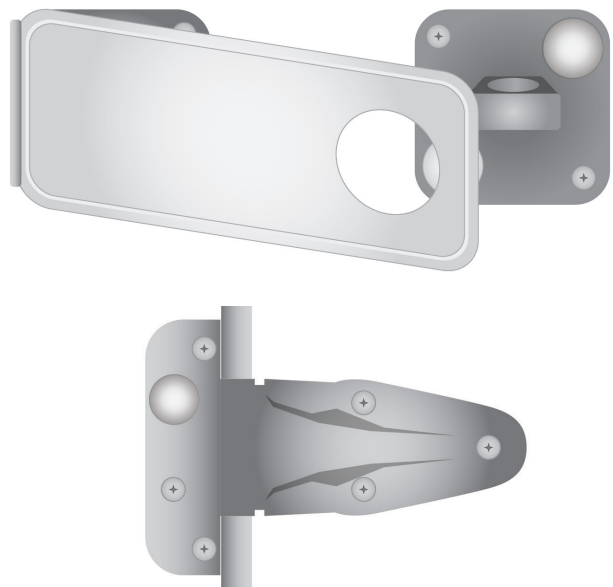



---

## Drip Cap

**Features** Aluminum Cap that attaches to the horizontal, exterior trim just above the door. Extends just beyond the width of the door.

**Benefits** Protects against rainwater leaking inside the shed through the top of the door opening.

**Availability** Offered as an upgrade to doors in 3', 4' and 6' widths. Available only in white.

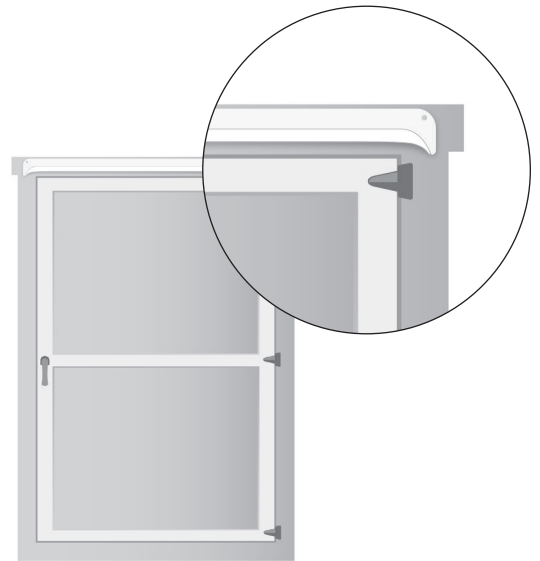



---

## Regular Duty Ramps and Sill Nose

**Features** One pair of regular duty, removable ramps, plus sill nosing. Each ramp measures 8" x 36"

**Benefits** Easier access for items on wheels. Ramps can be placed directly on top of sill nose, or in lower track position. The lower position allows door to be closed.

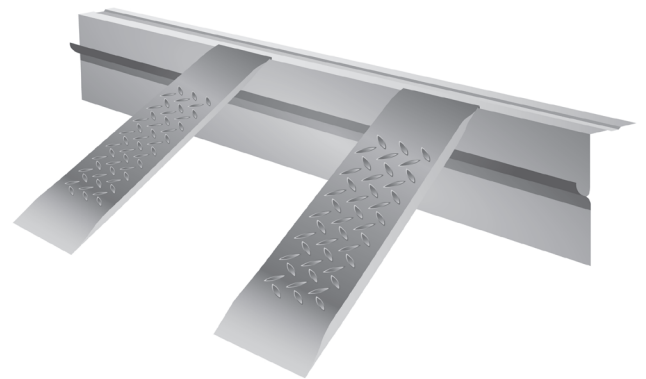
**Availability** Offered as an upgrade to all single and double shed doors. Additional single ramps can be added to order.



---

## Heavy Duty Ramps and Sill Nose

**Features** One pair of heavy duty, removable ramps, plus sill nosing with two ramp-hanging heights. Each ramp is 23" wide by 42" long.

---

**Benefits** Can accommodate higher weight load (up to 1,200 pounds each) than regular duty ramps. Easier access for items on wheels. Two ramps designed to span opening of standard 4' wide shed door. Ramps can be placed at two different heights. Lower position allows door to be closed.

---

**Availability** Offered as an upgrade to all single and double shed doors. Additional single ramps can be added to order when upgrading to double shed door.

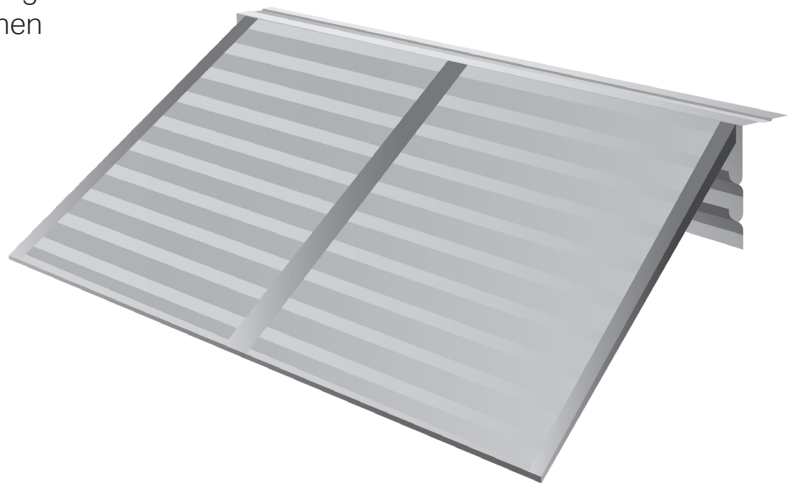



# ENTRY DOORS

---

---

## 6-Panel Entry Door

**Features** 3' wide x 6'8" tall exterior, in-swing entry door with lockable knob handle and deadbolt. Manufacturer's color, typically white. Comes with manufacturer's door jamb and aluminum door threshold and Tuff Shed exterior trim (LP® SmartSide).

---

**Benefits** Matches typical home construction. Lockable handle and deadbolt.

---

**Availability** One single 6-Panel door is standard on garages, and weekender models. Available as an upgrade on Premier Series® and Premier PRO Series™ Tall Ranch and Tall Barn shed models. Placement options vary by model and size. Painting of this door not available. Choose hinge side and swing direction (i.e. Left Hand Inswing, Right Hand Outswing, etc.). Note that outswing doors may have longer lead times and higher costs.



---

## 9-Lite Entry Door

**Features** 3' wide x 6'8" tall exterior entry door with lockable knob handle and deadbolt, plus tempered glass window separated into 9 panes in upper portion of door. Manufacturer's color, typically white. Comes with manufacturer's door jamb and aluminum door threshold and Tuff Shed exterior trim (LP® SmartSide).

---

**Benefits** Entry door that allows exterior light inside the building. Lockable handle and deadbolt.

---

**Availability** Available as an upgrade for standard 6-Panel Residential Door on garages and weekender models. Available as upgrade on Premier Series® and Premier PRO Series™ Tall Ranch and Tall Barn shed models. Placement options vary by model and size. Painting of this door not available.



---

## Fan-Lite Entry Door

**Features** 3' wide x 6'8" tall exterior residential door with lockable knob handle and deadbolt, plus tempered glass semicircle window in upper portion of door. Manufacturer's color, typically white. Comes with manufacturer's door jamb and aluminum door threshold and Tuff Shed exterior trim (LP® SmartSide).

**Benefits** Entry door that allows exterior light inside the building. Lockable handle and deadbolt.

**Availability** Available as an upgrade for standard 6-Panel Entry Door on garages and weekender models. Available as upgrade on Premier Series® and Premier PRO Series™ Tall Ranch and Tall Barn shed models. Placement options vary by model and size. Painting of this door not available.



---

## Full-Lite Entry Door

**Features** 3' wide x 6'8" tall exterior entry door with lockable knob handle and deadbolt, plus single, large tempered glass window. Manufacturer's color, typically white. Comes with manufacturer's door jamb and aluminum door threshold and Tuff Shed exterior trim (LP® SmartSide).

**Benefits** Entry door with large window allowing maximum exterior light inside the building. Lockable handle and deadbolt.

**Availability** Available as an upgrade for standard 6-Panel Entry Door on garages and weekender models. Available as upgrade on Premier Series® and Premier PRO Series™ Tall Ranch and Tall Barn shed models. (One single Full-Lite Entry Door is standard on PRO Studio Model). Also available as a 6' x 6'8" double door upgrade. Placement options vary by model and size. Painting of this door not available.



## Sliding Glass Door

**Features** 6' wide x 6'8" tall Exterior Sliding Glass Entry Door with lockable handle. Includes one stationary glass section, one sliding glass section, and one sliding screen section. Manufacturer's color, typically white. Comes with manufacturer's door jamb, aluminum door threshold and sliding track and Tuff Shed exterior trim (LP® SmartSide).

**Benefits** Sliding entry door with large window allowing maximum exterior light inside the building. Lockable handle.

**Availability** Available as an upgrade on Premier Series® and Premier PRO Series™ Tall Ranch and Tall Barn shed models. Placement options vary by model and size. Painting of this door not available.

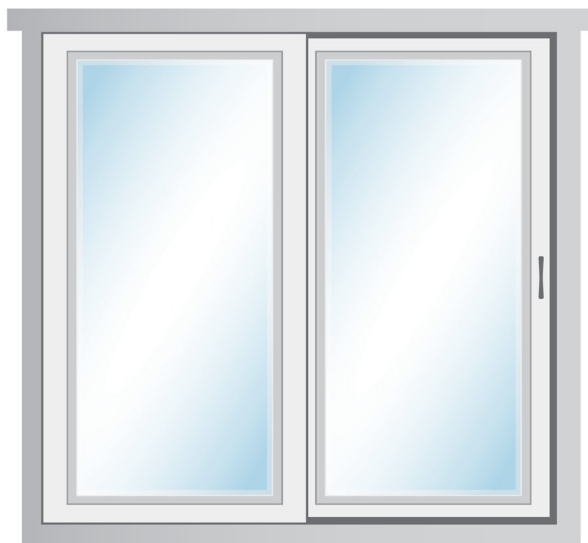

## Full-Lite Double Door

**Features** Double entry doors with combined opening measuring 6' wide x 6'8" tall. Main door includes lockable knob handle and deadbolt. Secondary door is latched in place by hardware at the top and bottom of the door, and can be opened. Both doors have a single, large tempered glass window. Manufacturer's color, typically white. Comes with manufacturer's door jamb and aluminum door threshold and Tuff Shed exterior trim (LP® SmartSide).

**Benefits** Entry doors with large window allow maximum exterior light inside the building. Wider door opening allowing easier access for larger items. Curb appeal with a more residential appearance.

**Availability** Available as an upgrade for standard 6-Panel Entry Door on garages and weekender models. Available as upgrade on Premier Series® and Premier PRO Series™ Tall Ranch and Tall Barn shed models. Placement options vary by model and size. Painting of this door not available.

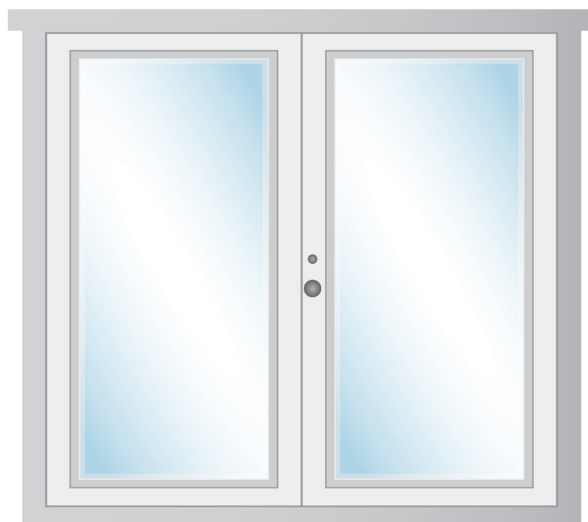

# GARAGE DOORS

---

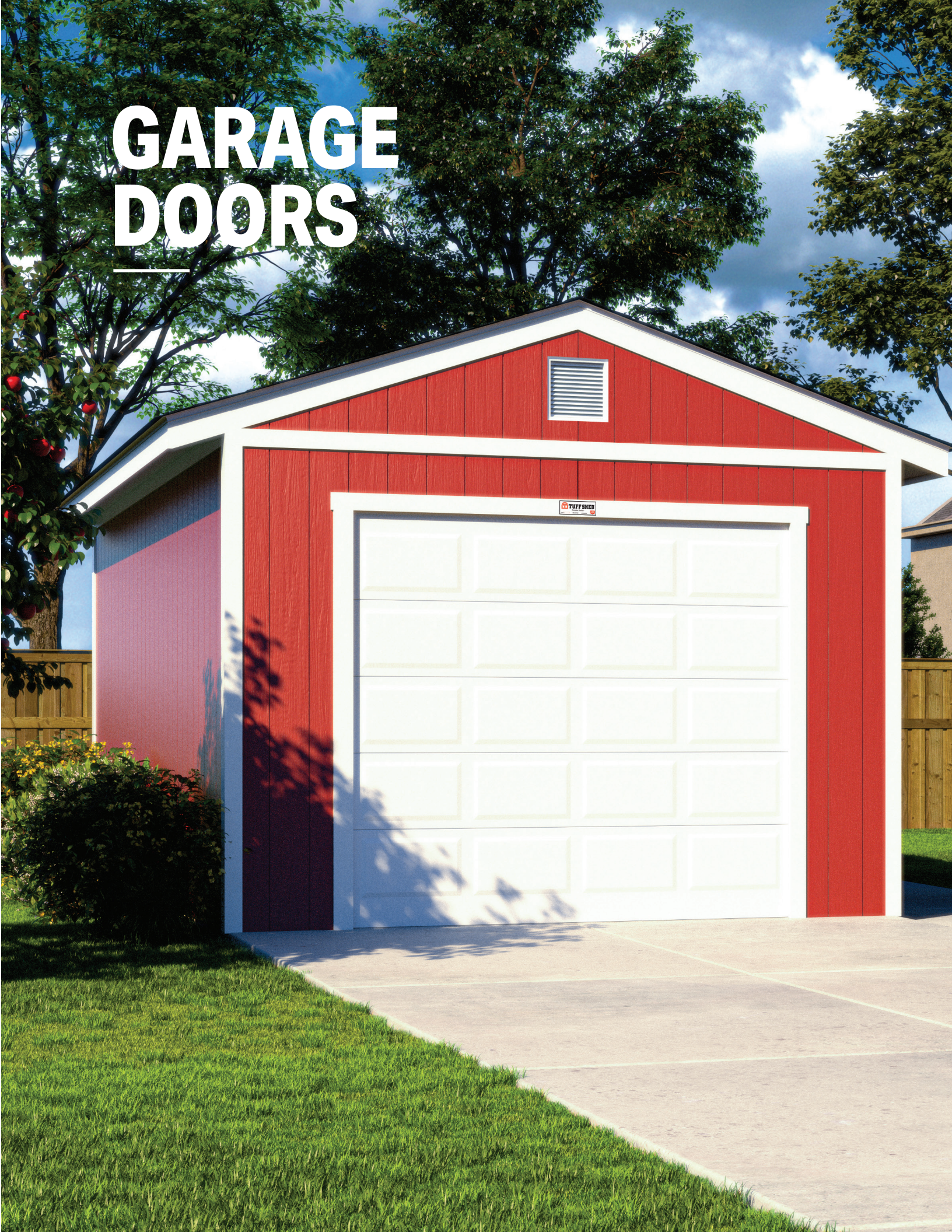

---

## Overhead Garage Door

**Features** Steel door in 7' standard height, and variety of widths (8' wide, 10' wide, 12' wide and 16' wide), depending on building size and door placement. Manufacturer's color, typically white. Standard extension springs and bottom weather seal.

**Benefits** Seals to floor and is compatible with automatic garage door openers.

**Availability** One Overhead Garage door (7' height and up to 16' wide) is standard on Premier Series® and Premier PRO Series™ garage models. Additional Overhead Garage Door and Door Height upgrades also available.

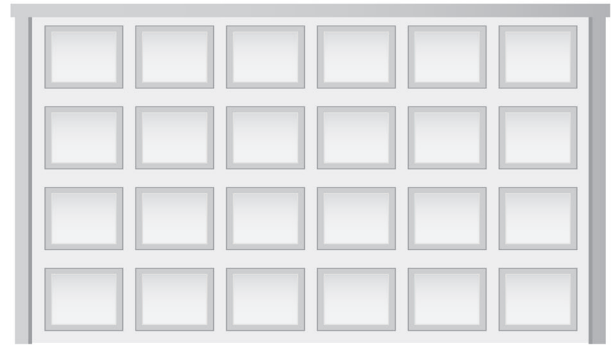

---

## Insulated Garage Door

**Features** Standard Overhead Garage Door plus polystyrene insulation.

**Benefits** More stable year-round garage temperature, plus quieter operation and added durability.

**Availability** Upgrade offered on Premier Series® and Premier PRO Series™ Garages.

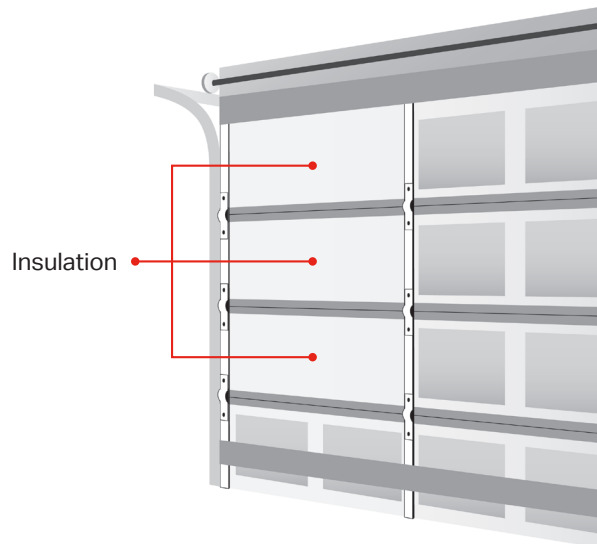



---

## Black Door Hardware

**Features** Decorative black exterior hinges.

**Benefits** Curb appeal.

**Availability** Upgrade offered on Premier Series® and Premier PRO Series™ Garages.

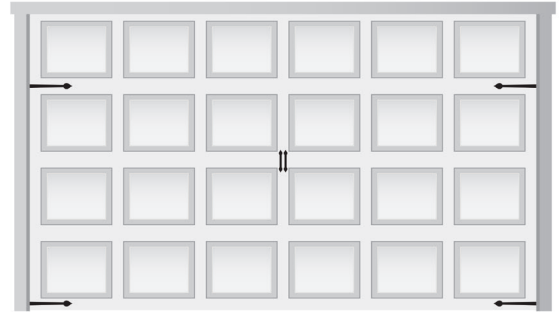

---

## Glass Top Panel

**Features** Glass inserts on top row of Overhead Garage Doors.

**Benefits** Adds curb appeal and allows exterior light inside the building.

**Availability** Upgrade offered on Premier Series® and Premier PRO Series™ Garages.





The Premier PRO Series™ Ranch Garage features 12" Endwall Eaves and Ridge Vent as standard.



# WINDOWS

---

---

## 2' x 2' Insulated Horizontal Sliding Window

**Features** Vinyl clad, insulated locking window with operable horizontal sliding section and removable screen.

**Benefits** Adds curb appeal and allows exterior light inside the building, while maintaining more stable interior temperature.

**Availability** Available on all models. Placement options depend on building style and size.

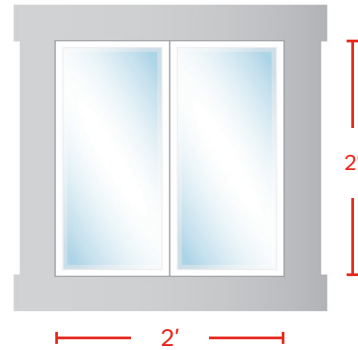

---

## 3' x 2' Insulated Horizontal Sliding Window

**Features** Vinyl clad, insulated locking window with operable horizontal sliding section and removable screen.

**Benefits** Adds curb appeal and allows exterior light inside the building, while maintaining more stable interior temperature.

**Availability** Available on all models. Placement options depend on building style and size.

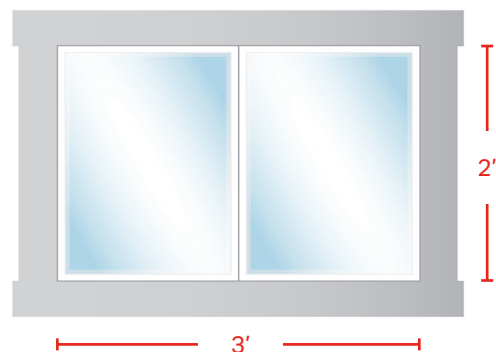

### 3' x 3' Insulated Horizontal Sliding Window

**Features** Vinyl clad, insulated locking window with operable horizontal sliding section and removable screen.

**Benefits** Adds curb appeal and allows exterior light inside the building, while maintaining more stable interior temperature.

**Availability** Available on all models. Placement options depend on building style and size.

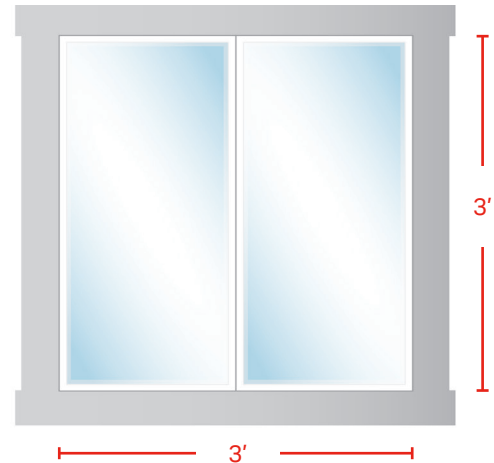

### 4' x 3' Insulated Horizontal Sliding Window

**Features** Vinyl clad, insulated locking window with operable horizontal sliding section and removable screen.

**Benefits** Adds curb appeal and allows exterior light inside the building, while maintaining more stable interior temperature.

**Availability** Available on all models. Placement options depend on building style and size.

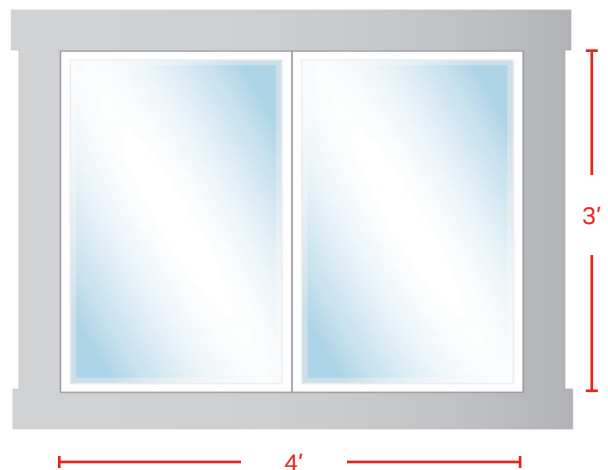

---

## Window Shutters

**Features** Stationary 2' tall or 3' tall Window Shutters, constructed of LP® SmartSide® Trim. Can be painted same color as trim or a third, accent paint color.

---

**Benefits** Adds curb appeal.

---

**Availability** Sold in pairs. Can be added to all Horizontal Sliding Windows. Height corresponds with window height. May not be available on some window placements due to limited wall space.

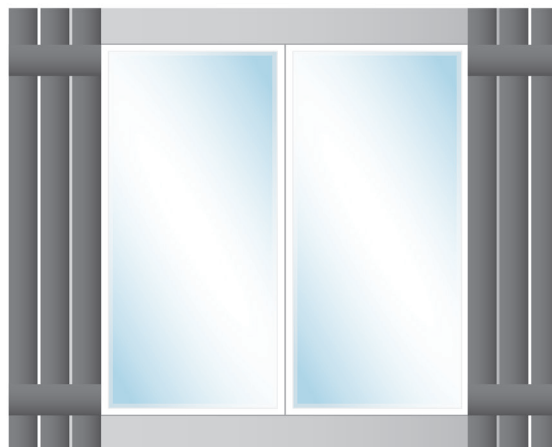

---

## Premium Vinyl Window Box

**Features** High quality molded polyethylene with large built-in water reservoir. Includes steel wall mounting brackets.

---

**Benefits** Water reservoir keeps plants irrigated for extended period. Black color with UV inhibitors resists fading. Mounting brackets allow for easy seasonal removal/storage of unit.

---

**Availability** Offered in 2' wide and 3' wide and installed on Tuff Shed buildings beneath Horizontal Sliding Windows.

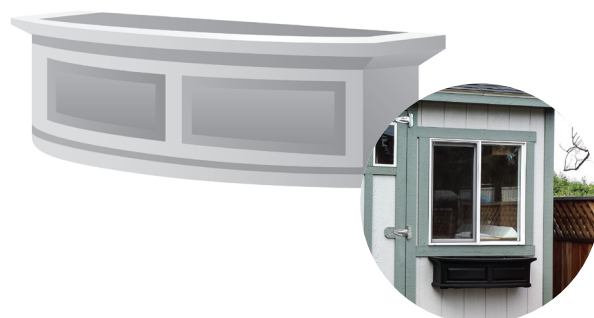

# 16" x 8" Transom Window

**Features** Stationary, insulated, tempered transom window.

**Benefits** Adds curb appeal and allows exterior light inside the building.

**Availability** Can be added to shed doors (vertical placement in top panel), above the door on some models and on walls on all Premier Series® and Premier PRO Series™ models. Placement options depend on building style, size and configuration.

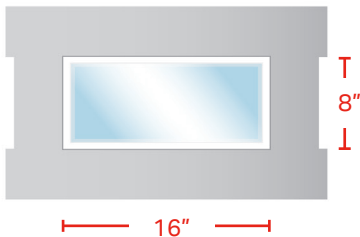

3 Transom Windows above 4' wide door

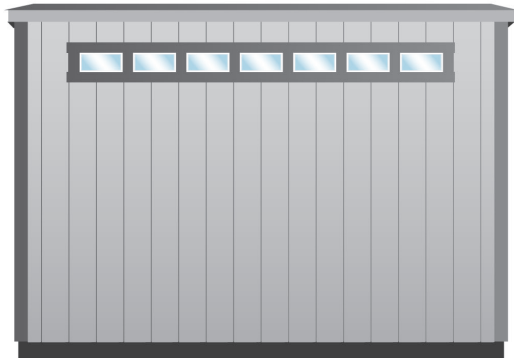

16" Transom Windows placed in every bay on sidewall



4 Transom Windows above 6' wide double door

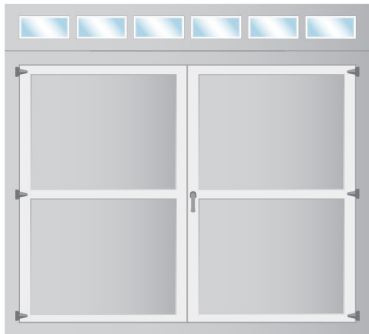

6 Transom Windows above 8' wide double door

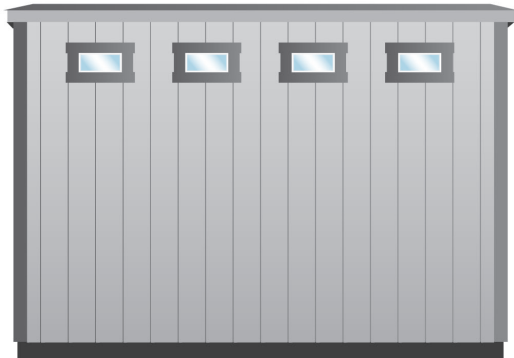

16" Transom Windows placed in every other bay on sidewall

## 29" x 8" and 41" x 8" Transom Windows

**Features** Stationary, insulated, tempered transom window.

**Benefits** Adds curb appeal and allows exterior light inside the building.

**Availability** Can be added to walls of Premier Series® and Premier PRO Series™ buildings. Placement options depend on building style, size and configuration.

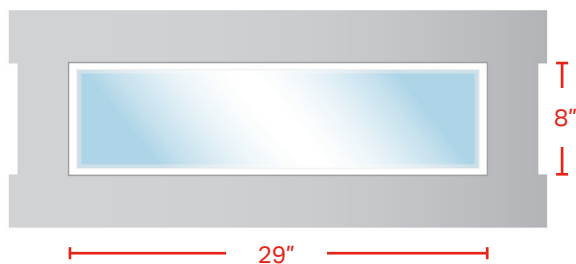

29" Transom Windows spaced evenly on sidewall



41" Transom Windows spaced evenly on sidewall



## 2' x 2' and 2' x 4' Skylight

**Features** Steel frame and flange with high-impact lens.

**Benefits** Bring the sun's natural light inside the building. Virtually unbreakable lens.

**Availability** Can be added to most Tuff Shed buildings with minimum roof pitch of 4/12. Not available with metal roof upgrade. Placement options depend on building type and size.

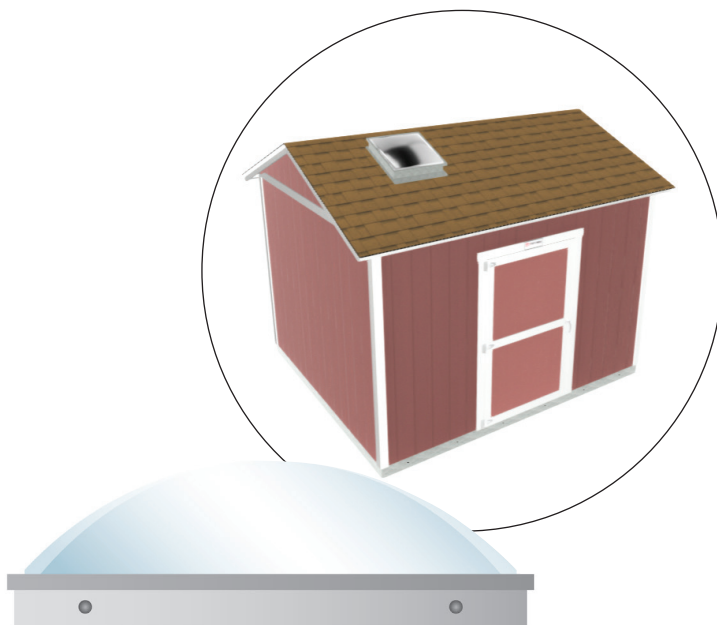

2'x2' Skylight shown  
on Ranch Style Roof



2'x4' Skylight shown  
on Ranch Style Roof



Premier PRO Series™ Tall Barn with French Doors, 2'x2' Insulated Window and Shutters. This building was configured with a "no floor" option and placed directly on a custom, 'two-part pour' concrete pad, supplied by the customer.

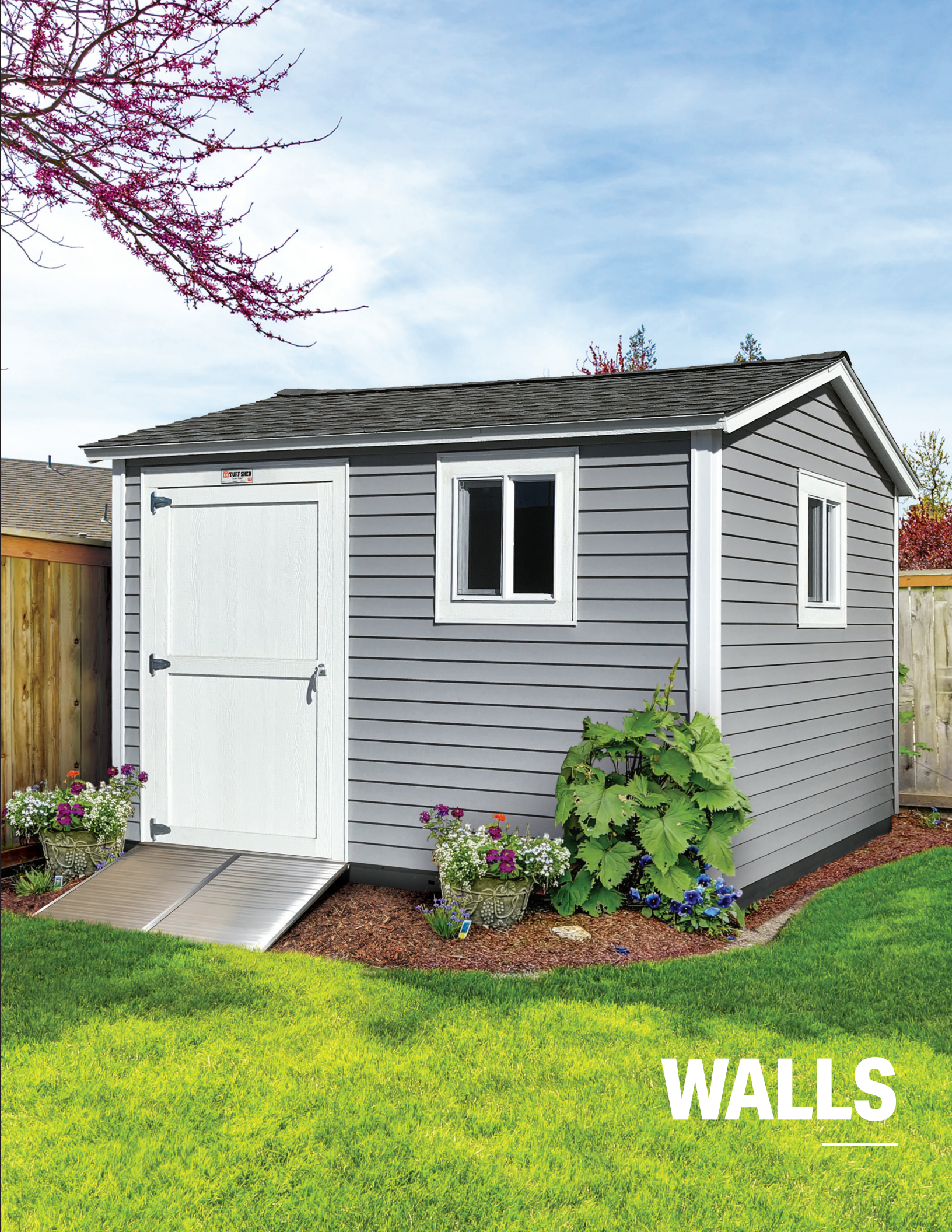

**WALLS**

---

---

## LP® Lap Siding

**Features** Horizontal, LP® SmartSide treated Lap Siding. Requires OSB wall sheathing and house wrap vapor barrier.

---

**Benefits** Curb appeal.

---

**Availability** Offered as an upgrade to all single story buildings.

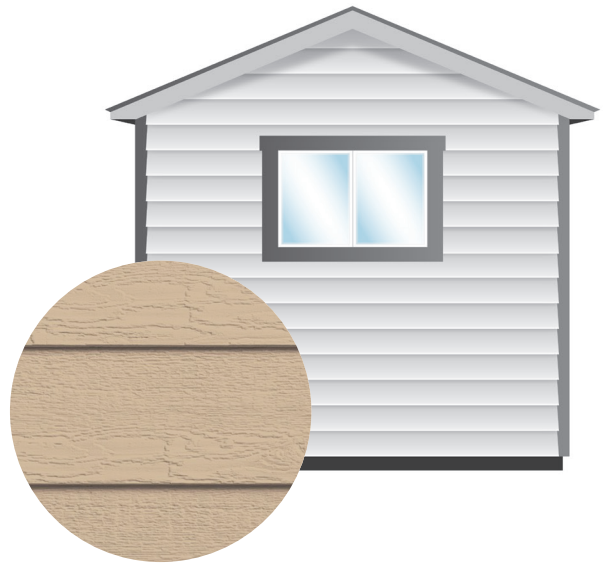

---

## Cement Lap Siding

**Features** Cement panel siding requires OSB wall sheathing and house wrap vapor barrier.

---

**Benefits** Fire-resistant material. Can provide closer match to some residential structures, and is required by some HOAs.

---

**Availability** Offered as an upgrade to all single story buildings.



---

## Cement Panel Siding

**Features** Cement panel siding from James Hardie® Requires house wrap vapor barrier.

---

**Benefits** Fire-resistant material. Can provide closer match to some residential structures, and is required by some HOAs.

---

**Availability** Offered as an upgrade to all single story buildings.

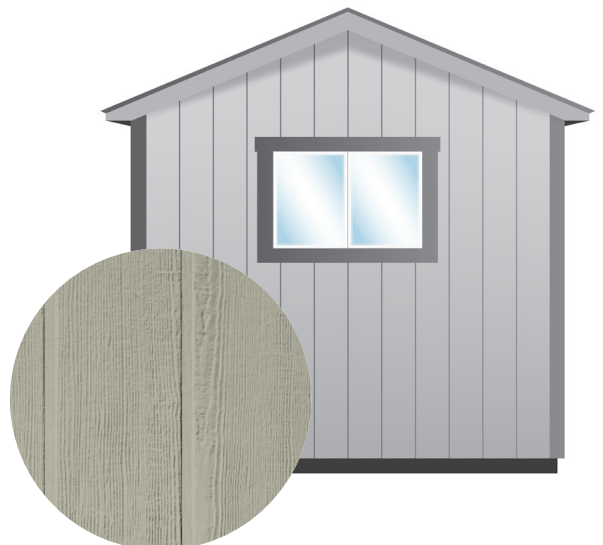

## 2x6 Wall Framing Upgrade

- Features** Upgrades 2x4 standard wood wall framing with 2x6 wood wall framing.

---

- Benefits** Deeper exterior walls allow customer to add thicker insulation material.

---

- Availability** Offered as an upgrade to all Premier Series® and Premier PRO Series™ buildings. This upgrade may be required for Wall Height upgrade (sold separately).

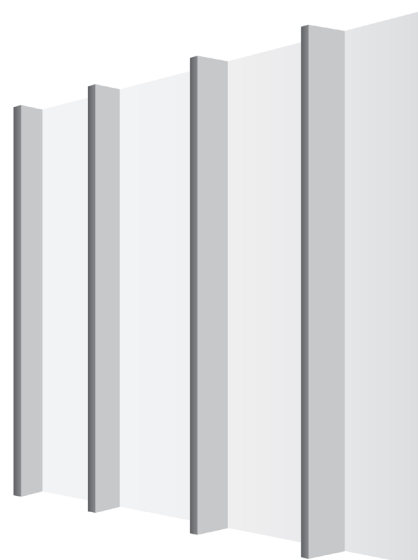

## House Wrap

- Features** Synthetic vapor barrier.

---

- Benefits** Provides moisture barrier to better protect your structure.

---

- Availability** Must be added to any building when customer selects siding upgrade or plans to insulate building.



## Paint

- Features** Two coats of quality Glidden Professional Paint.

---

- Benefits** Protects wood surface on building exterior. Added curb appeal.

---

- Availability** Many colors available. Seasonal 1-coat paint discount available (customer is supplied with touch up paint, brush and roller).



## Wall Height Upgrades

**Features** Add wall height to select models.

**Benefits** Taller walls allow for additional cubic feet of storage.

**Availability** Offered as an upgrade on models with 8' tall walls (Premier Series® Tall Ranch, Premier PRO Series™ Tall Ranch, Premier PRO Series™ Tall Barn, Premier PRO Series™ Weekenders, and Premier® and Premier PRO Series™ garages). Customer can select wall height upgrade in 1' increments up to an additional 8' of height. This upgrade may require Wall Framing upgrade (sold separately).

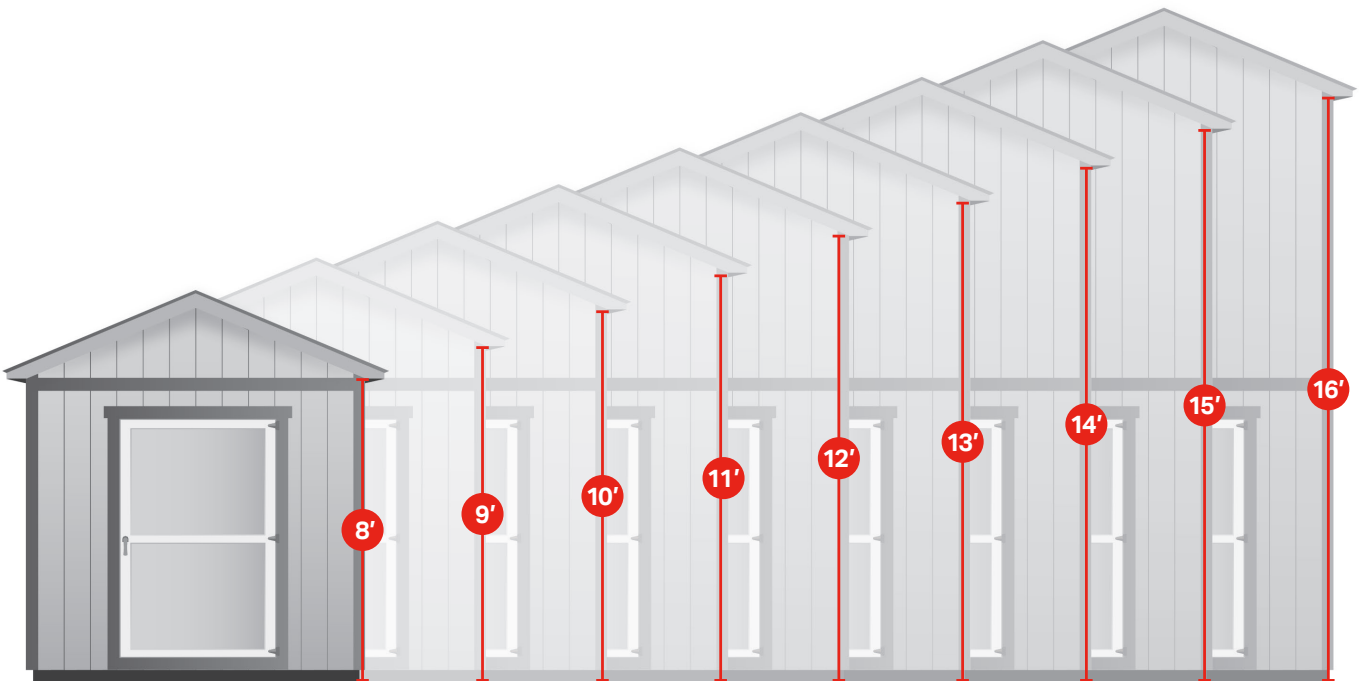

Premier PRO Tall Ranch Shown with 1' increments of Wall Height Upgrades

# VENTILATION

---

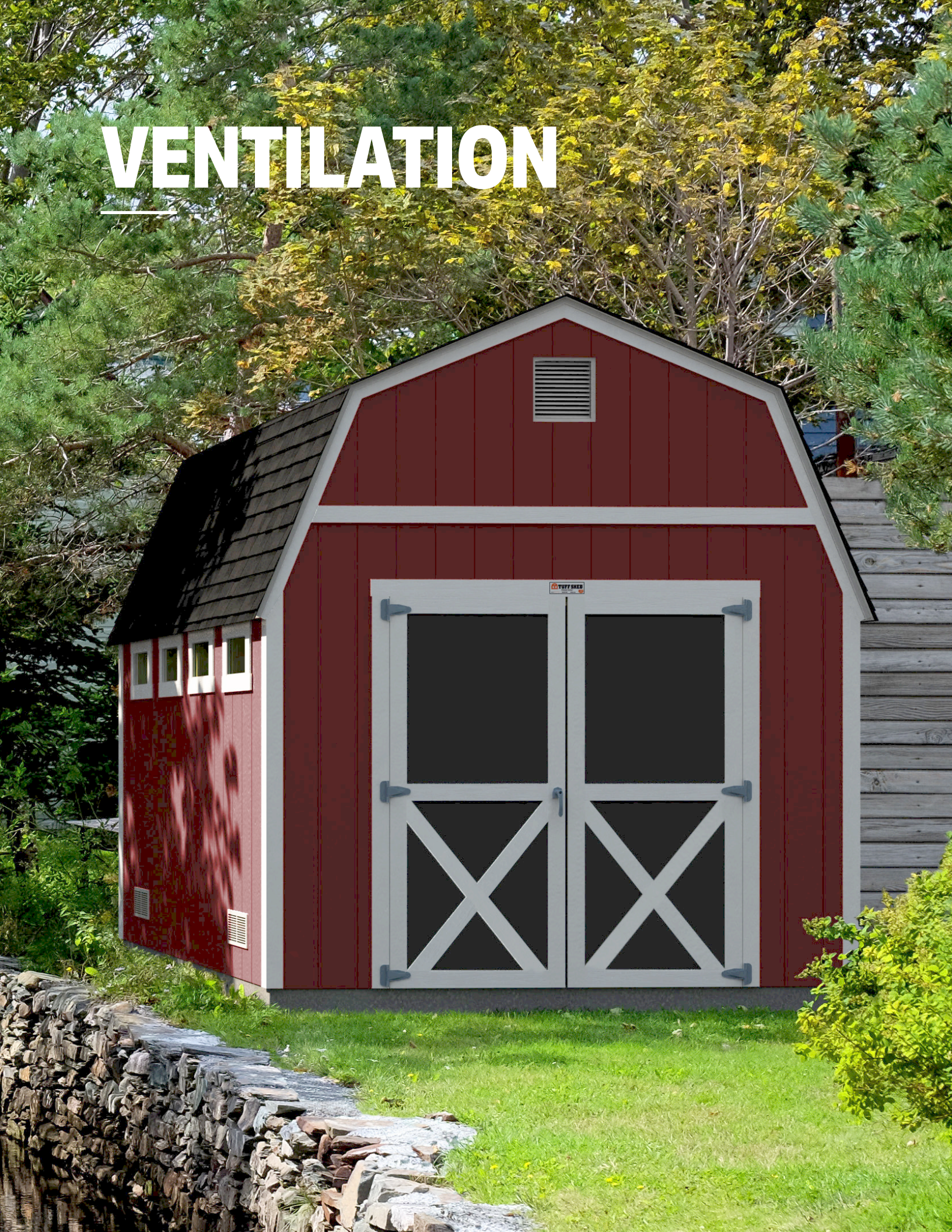

---

## 16" x 8" Wall Vent

**Features** 16" wide x 8" tall Tuff Shed-branded, snap in place high-impact vinyl wall vent with screen.

**Benefits** Helps create airflow in the building, while keeping insects out.

**Availability** Most popular standard wall vent size. Available as an upgrade to all buildings, in white or brown.

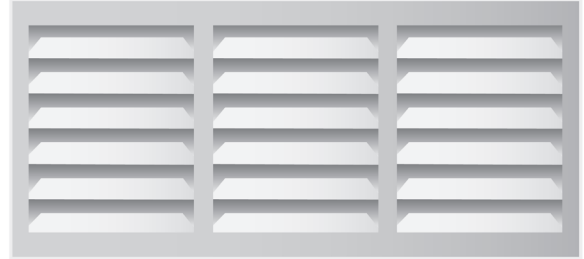

---

## 16" x 4" Wall Vent

**Features** 16" wide x 4" tall Tuff Shed-branded, snap in place high-impact vinyl wall vent with screen.

**Benefits** Helps create airflow in the building, while keeping insects out.

**Availability** Shorter standard wall vent, can fit in tight spaces like above the door on smaller models/sizes. Available as an upgrade to all buildings, in white or brown.

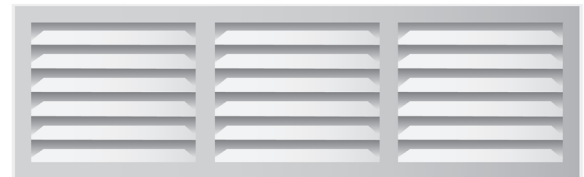



## 12" x 12" Wall Vent

**Features** 12" wide x 12" tall Tuff Shed-branded, snap in place high-impact vinyl wall vent with screen.

**Benefits** Helps create airflow in the building, while keeping insects out.

**Availability** Square standard wall vent, typically placed in upper gable near the peak. Available as an upgrade to all buildings, in white or brown.

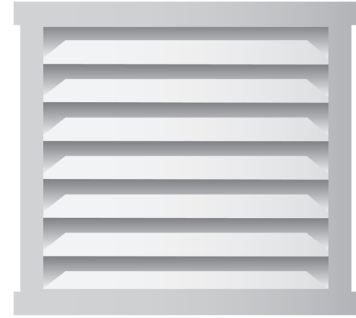

## Flood Vent

**Features** Placed on the wall near the base of the building. This item varies in size and style by market.

**Benefits** Allows for flood water to move through the building .

**Availability** Offered as an upgrade to all buildings. Typically selected only when required in flood zones. Number of vents varies by market and building size.

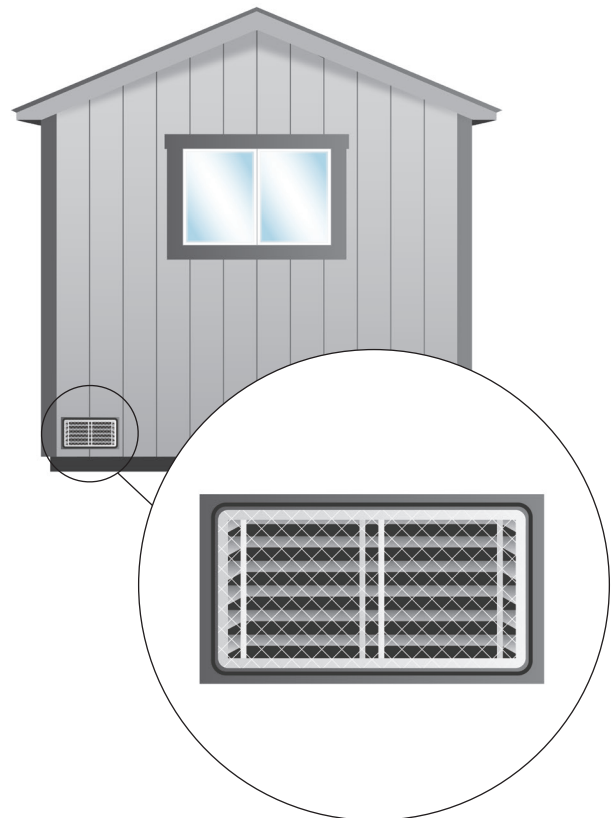

---

## Ridge Vent

**Features** Installed the entire length of the roof at the roof ridge. This composite material is rolled out over the peak and then shingled over.

**Benefits** Allows hot air and moisture to escape the building at the roof peak with external baffles to deflect wind and rain. Works best when accompanied by wall vents.

**Availability** Standard on Premier PRO Ranch Garage. Offered as an upgrade on all other buildings except models with single slope roof (i.e. PRO Studio, Premier Lean-To).

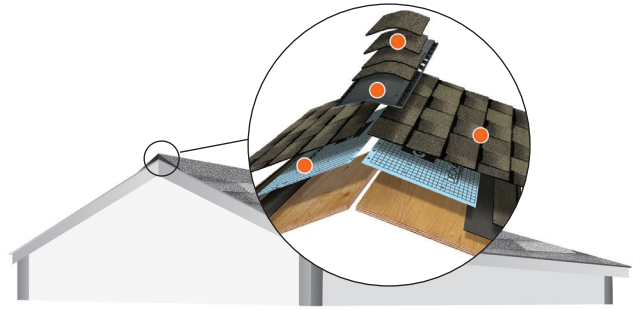

---

## Metal Roof Vent

**Features** Square, metal vent fits over a small hole in the roof.

**Benefits** Allows heat to escape out of roof of building.

**Availability** Offered as an upgrade to all buildings except models with less than 3/12 roof pitch.

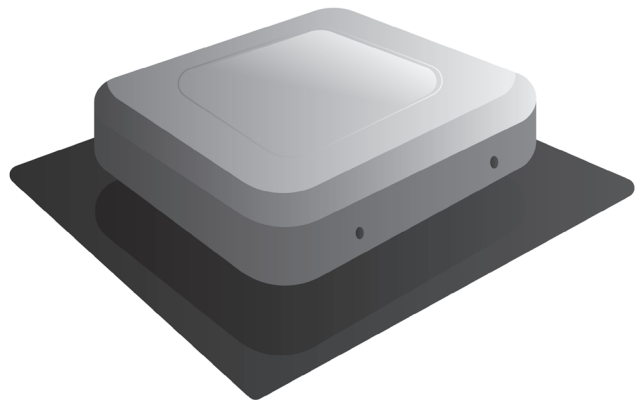



**ORGANIZATION**

---

---

## Shelving

**Features** Shelf constructed of heavy-duty 2x4 wood brackets attached at every other wall stud and topped with 7/16" thick sheathing.

**Benefits** Added storage space with convenient, off-the-ground location.

**Availability** Offered as an upgrade to all buildings. Choose from 12", 16", or 24" depths. Designed to run the full length of a wall. Can be added in multiple layers.

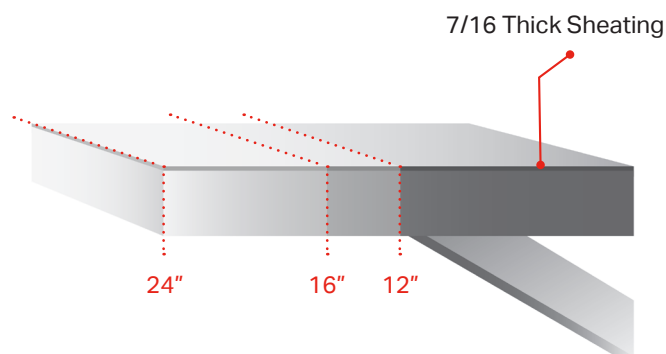

---

## 24" Deep Workbench

**Features** 24" deep workbench constructed of heavy-duty 2x4 wood brackets attached at every wall stud and topped with 3/4" thick sheathing.

**Benefits** Larger, more durable work surface.

**Availability** Offered as an upgrade to all buildings.

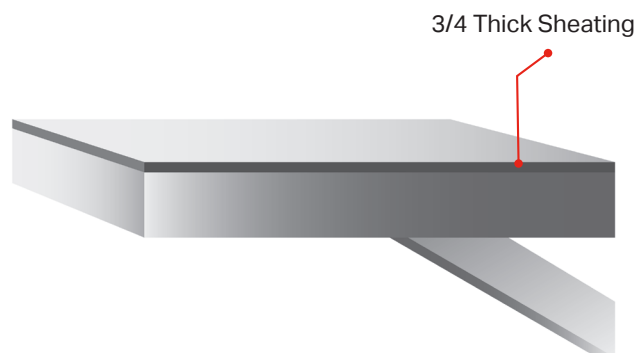

## Pegboard

**Features** White finish pegboard spanning length of interior sidewall or endwall.

**Benefits** More finished looking interior. Accommodates pegboard hooks for additional organization.

**Availability** Offered as an upgrade to all buildings. Can be placed on full wall height, half wall height, or above workbench (as shown here).

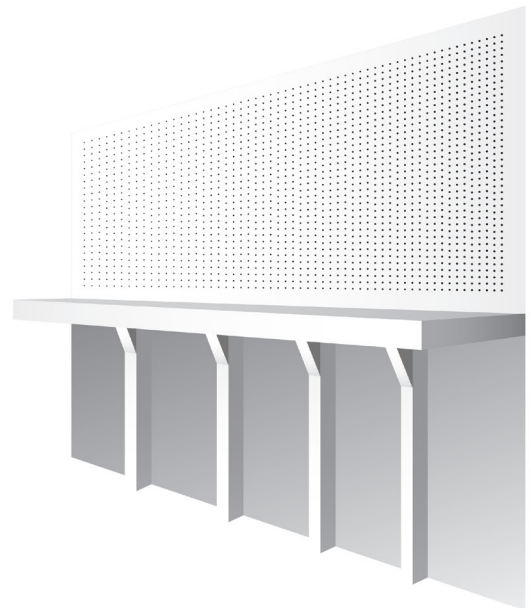

## Overhead Loft

**Features** Overhead Loft with 3/4" thick floor decking supported by dimensional lumber joists (2x6, 2x8 or 2x12 depending on building width). Designed to span entire width of building.

**Benefits** Add more storage space to the existing building footprint.

**Availability** Offered as an upgrade to barn sheds and garages and Premier Series® and Premier PRO Series™ Tall Ranch shed models. Available in a variety of configurations and depths in 2' increments.



Top view of potential loft configurations.



Premier Tall Barn interior featuring 24" shelving and overhead loft.

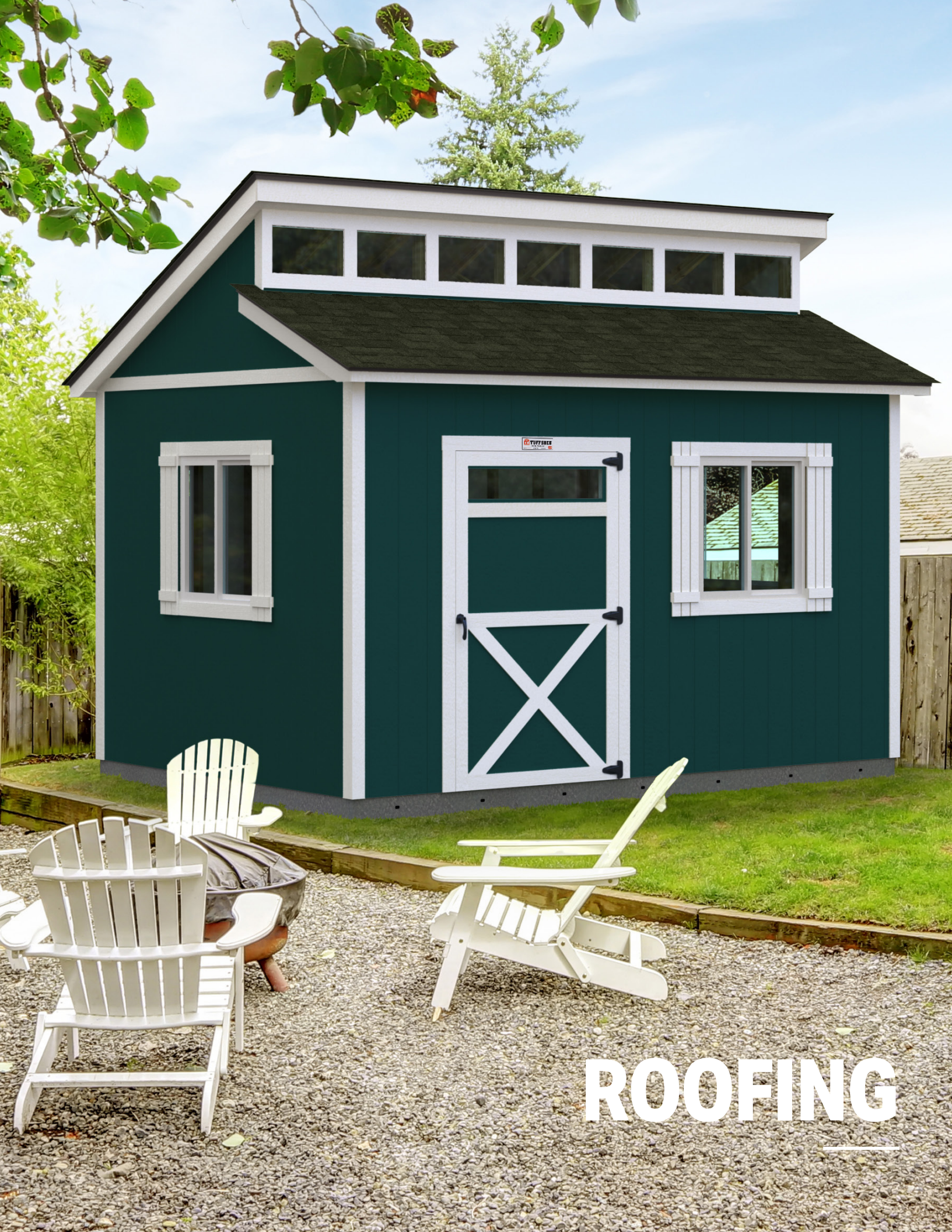

**ROOFING**

---

---

## Dimensional Shingles

**Features** Thick, fiberglass asphalt composition with cutting edge technology and 130 MPH Wind Rating and Manufacturer's Limited Lifetime Warranty.

---

**Benefits** Durability and style, with more vibrant colors and visual dimension.

---

**Availability** Offered as standard on Premier PRO Series™ buildings and as an upgrade on Garden Series® and Premier Series® buildings. Colors vary by market.

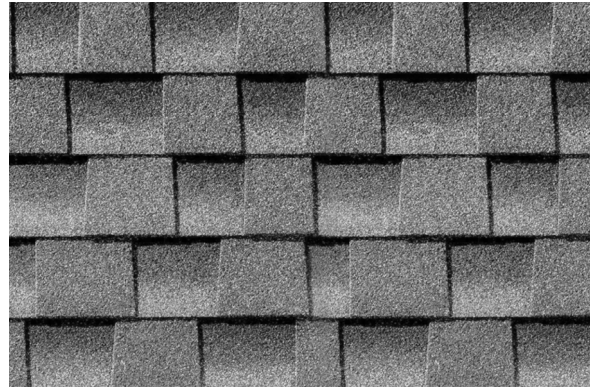

---

## Metal Roof

**Features** Ribbed metal roof panels with exposed fasteners.

---

**Benefits** Durability and style.

---

**Availability** Single story sheds. Color availability varies by market. Not available with most other roof upgrades. Not available in Florida

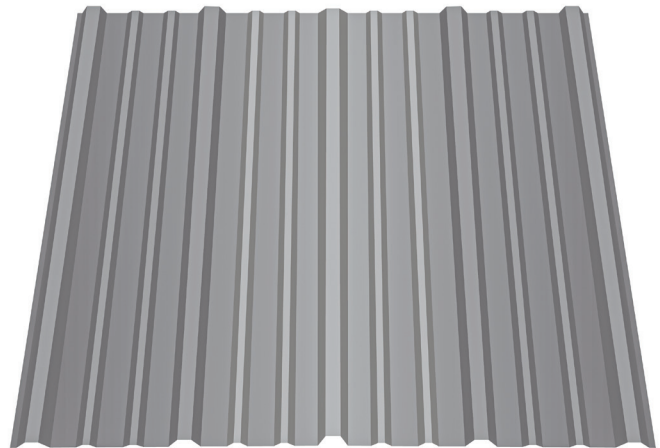



---

## Radiant Barrier Roof Decking

**Features** LP® SilverTech™ Radiant Barrier Technology.

**Benefits** Blocks much of sun's radiant heat from entering building. Also brightens building on the inside.

**Availability** Standard on Premier Series® and Premier PRO Series™. Available as an upgrade on Garden Series® sheds.

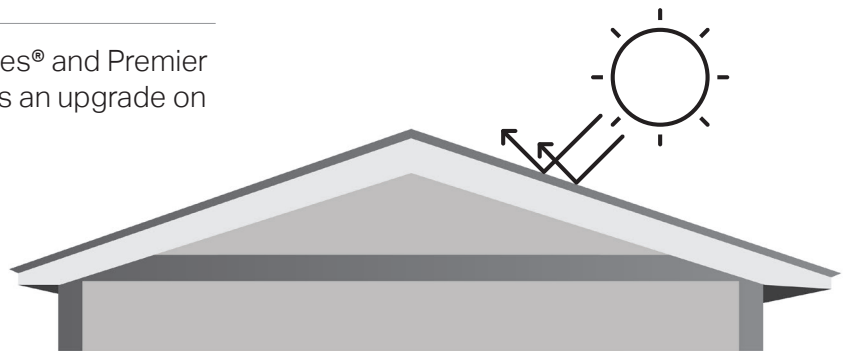



---

## Clerestory Roof

**Features** A single row of 20" transom windows that connects two separate roof sections.

**Benefits** Additional light on the inside and unique style outside.

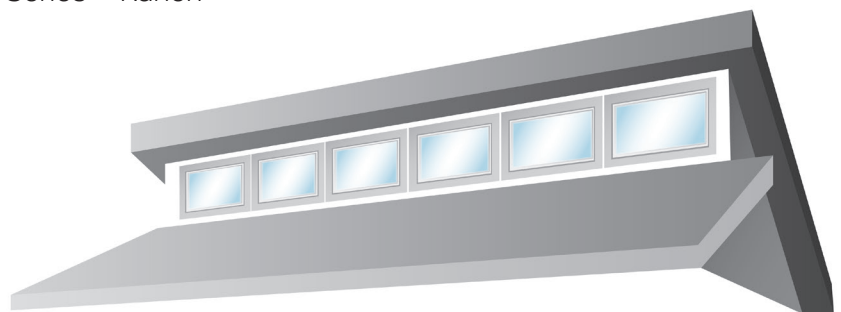
**Availability** Upgrade on Premier PRO Series™ Ranch and Tall Ranch.



## 5/12 Roof Pitch

**Features** Steeper roof pitch and higher peak.

**Benefits** Exterior style and more interior overhead space.

**Availability** Standard on Premier PRO Series™ buildings. Upgrade on Premier Series® and Garden Series® ranch style buildings.

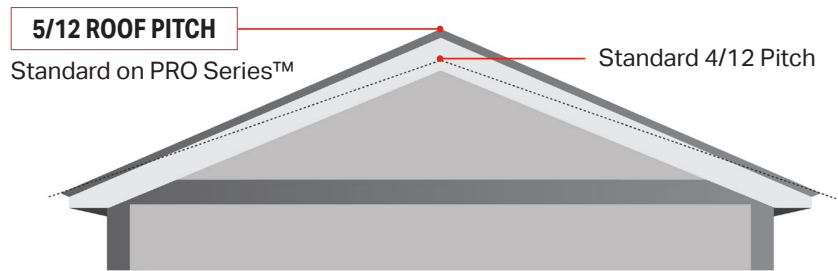

## 6/12 and 8/12 Roof Pitch

**Features** Steeper roof pitch and higher peak.

**Benefits** Exterior style and more interior overhead space.

**Availability** Upgrade on ranch style buildings.

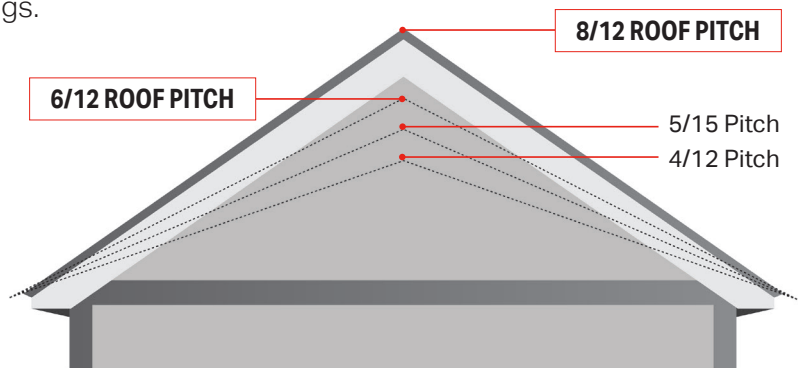

---

## Attic Truss Upgrade

**Features** Open space at the bottom center with webbing above and on either side. Bottom is sheathed with OSB.

---

**Benefits** Creates usable overhead storage space.

---

**Availability** Upgrade on Premier Series® and Premier PRO Series™ Ranch garage and shed models. Requires minimum building width of 16' wide and minimum roof pitch of 8/12.

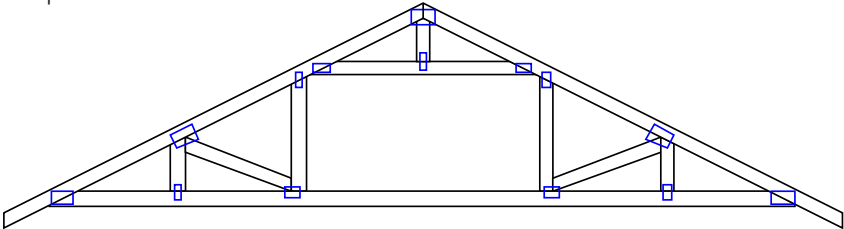

---

## Scissor Truss Upgrade

**Features** Replaces the bottom chord of truss, with two chords that angle upward from the bottom of the outside chords and join at the middle.

---

**Benefits** Creates vaulted overhead space.

---

**Availability** Upgrade on Premier Series® and Premier PRO Series™ Ranch garage and shed models. Requires minimum building width of 16' wide and minimum roof pitch of 5/12.

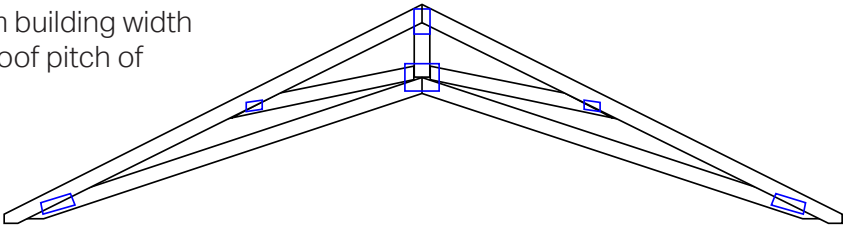

---

## 4" and 6" Gable Endwall Eave

**Features** Adds 4" (Premier Series® Ranch) or 6" (Premier Series® Tall Ranch) boxed eave overhand at the endwall.

**Benefits** Curb appeal. More closely resembles typical home construction.

**Availability** Upgrade on Premier Series® Ranch and Tall Ranch shed models.



---

## 12" Gable Endwall Eave

**Features** Adds 12" boxed eave overhang at the endwall.

**Benefits** Curb appeal. More closely resembles typical home construction.

**Availability** Standard on Premier PRO Series™ Ranch Garage. Upgrade on Premier Series® Ranch Garage.







tuffshed.com

1777 South Harrison Street, Suite 600, Denver, CO 80210  
Upgrades Catalog 2021

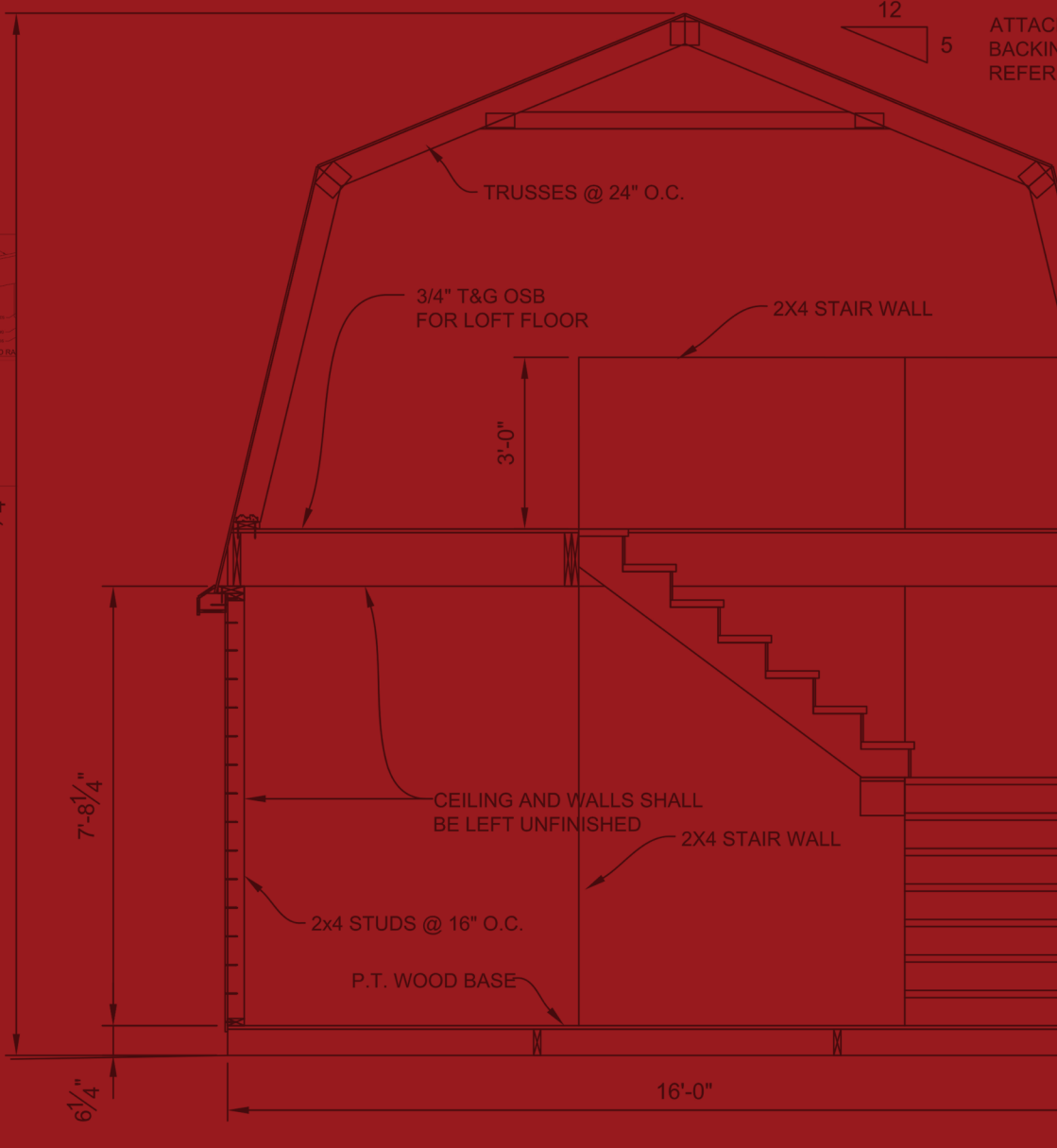
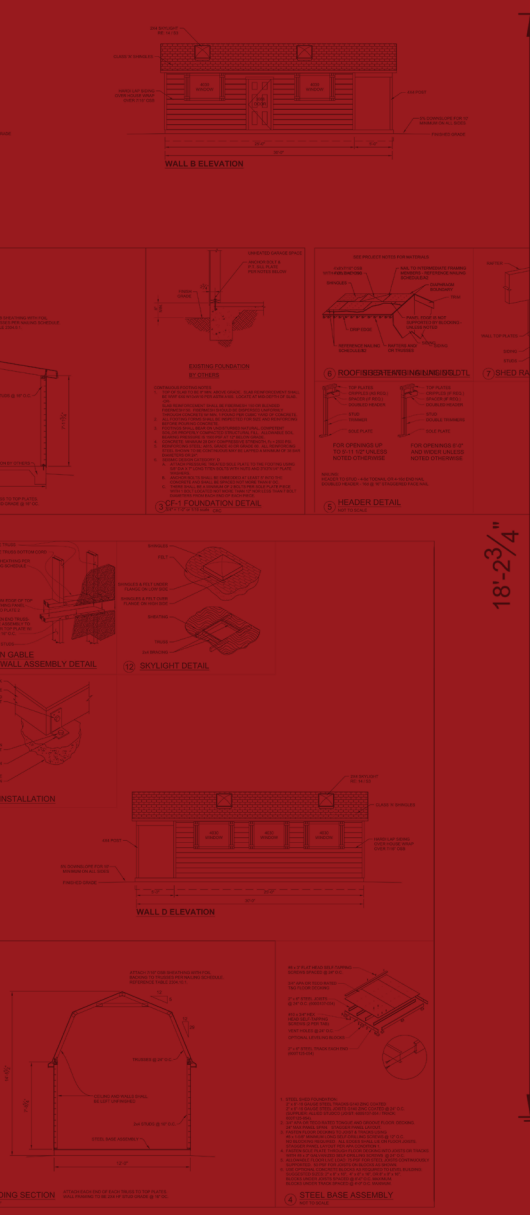
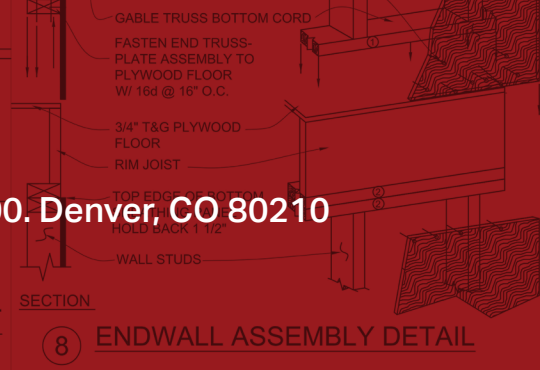

## 2 BUILDING SECTION

ATTACH EACH END OF EACH TRUSS TO TOP PLATES. WALL FRAMING TO BE 2X4 HF STUD GRADE @ 16" OC.

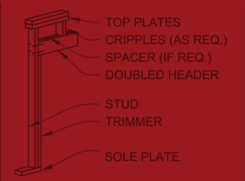
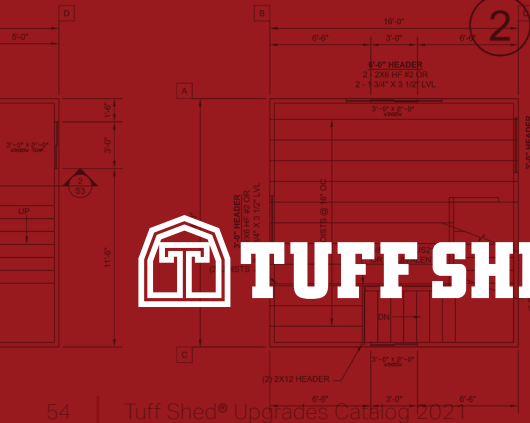

FOR OPENINGS UP TO 5'-11 1/2" UNLESS OTHERWISE NOTED

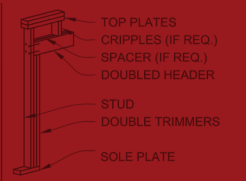

FOR OPENINGS 6'-0" AND WIDER UNLESS OTHERWISE NOTED

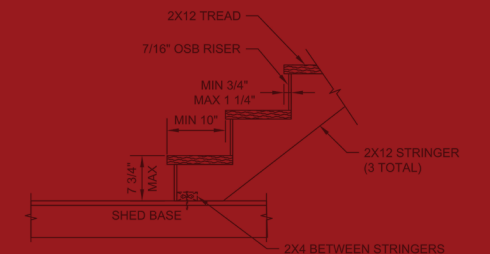

2X4 BETWEEN STRINGERS NAILED TO FLOOR (OR LANDING) WITH MINIMUM (5) 10D NAILS AND TO STRINGERS WITH (2) 10D NAILS, TYP.



UPDATED 2021

UPGRADES CATALOG



TH 7/16" OSB SHEATHING WITH FOIL  
 NG TO TRUSSES PER NAILING SCHEDULE.  
 NCE TABLE 2306.3.1.

12  
 50

SECURE ALL STRINGERS TO HEADER USING  
 SIMPSON (4) A35 ANGLE BRACKETS 1 EACH AT  
 ACCESSIBLE SIDE OF STRINGER (TYP AT LOWER  
 SET OF STRINGERS ON MID-LANDING, IF REQUIRED)

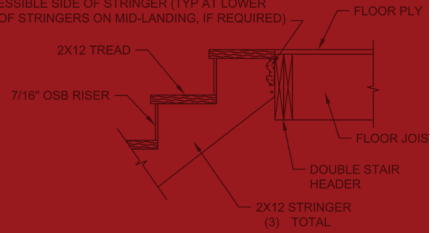
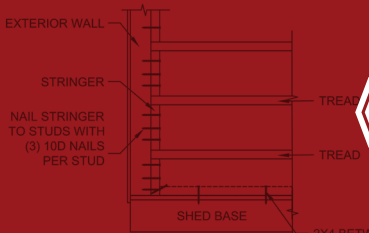

2X4 BETWEEN STRINGERS  
 NAILED TO FLOOR (OR LANDING)  
 WITH MINIMUM (5) 10D NAILS  
 AND TO STRINGERS  
 WITH (2) 10D NAILS, TYP.