

# Cabin Shells

The Colorado

864 sq ft | 1.5 Story

1 Bedroom | 1 or 2 Bathrooms

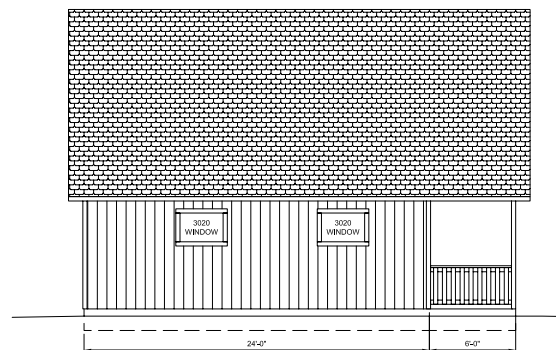
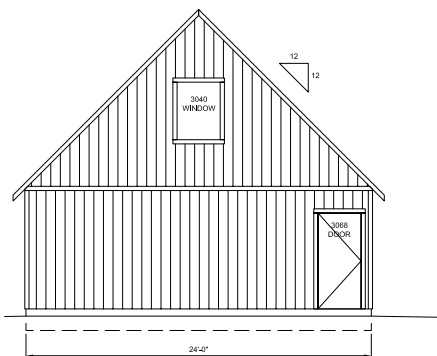
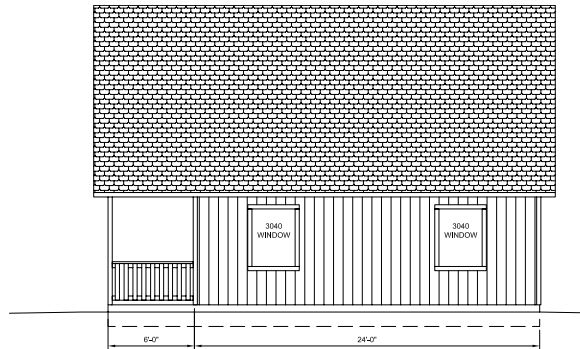
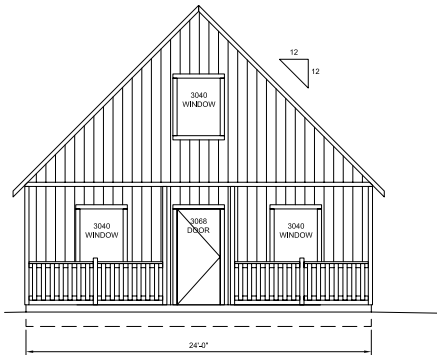

Effective June 2014



# TUFF SHED®

The Cabin Shell Series

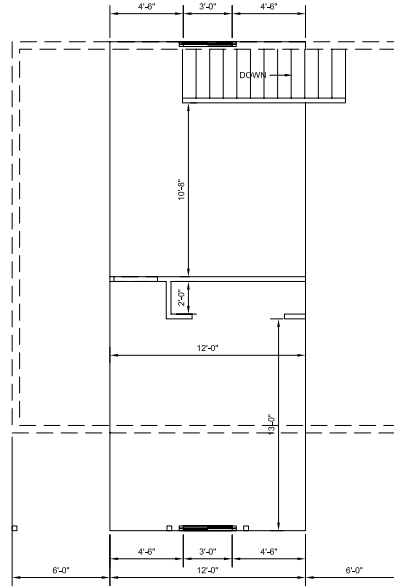
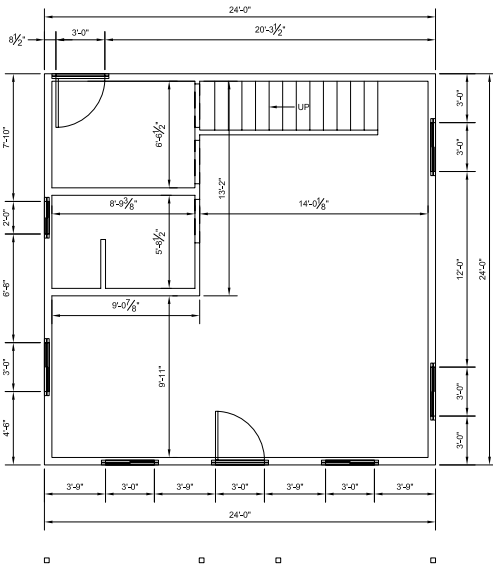

Standard Layout

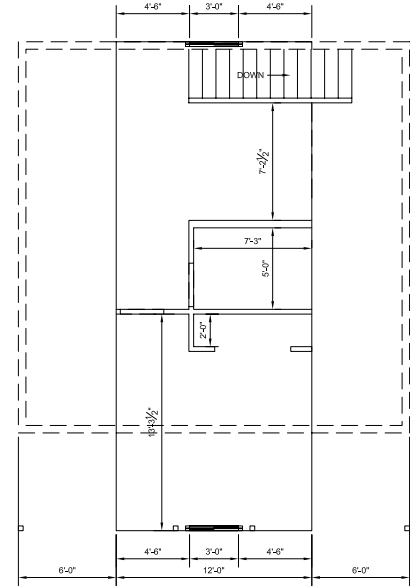

Opt. 2nd Bathroom

STANDARD FLOORPLAN

DOWNSTAIRS

UPSTAIRS

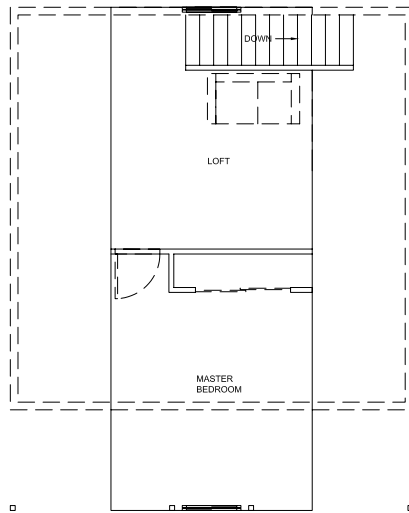
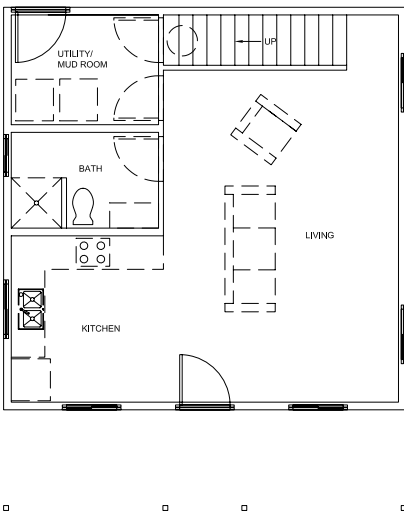

Standard Layout

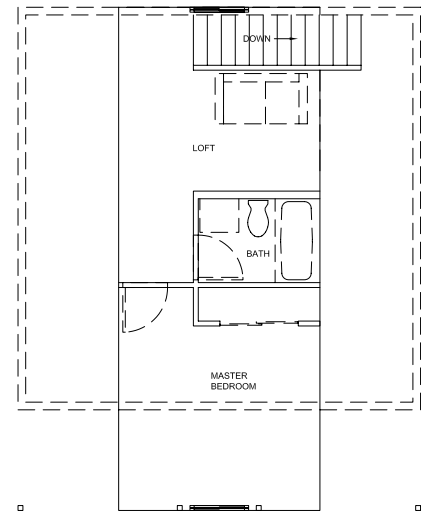

Opt. 2nd Bathroom

EXAMPLE FINISH

# Cabin Shells

## Options Pricing

| Description  | Retail     | UoM        |
|--|------------|------------|
| <b>Deck</b>  |            |            |
| Wood Floor - Exterior 2x6 Pressure Treated Decking                               | \$11.25    | Sq Ft      |
| Redwood/Cedar decking upgrade  | \$7.00     | Sq Ft      |
| Composite decking upgrade  | \$15.00    | Sq Ft      |
| Deck stairs - 4' wide and up to 4 steps max                                      | \$750.00   | Ea         |
| Deck railing   | \$17.00    | Ln Ft      |
| <b>Roof</b>  |            |            |
| Porch Roof (with valleys)  | \$30.00    | Sq Ft      |
| Porch Roof / Additional finished overhang attached to walls (without valleys)    | \$25.00    | Sq Ft      |
| Enclosed Bump Out (includes additional interior flooring)                        | \$46.00    | Sq Ft      |
| Dutch Gable Roof Framing   | \$15.00    | Sq Ft      |
| Dormer - Gable or Flat roof  | \$500.00   | Ln Ft      |
| Standing Seam Metal Roof - Ranch Roof Style                                      | \$3.25     | Sq Ft Roof |
| Standing Seam Metal Roof - Barn Roof Style                                       | \$4.00     | Sq Ft Roof |
| <b>Siding / Exterior Wall Framing</b>  |            |            |
| Hardie Plank Lap Siding w/Hardie Trim (Will Increase Paint Cost)                 | \$4.75     | Sq Ft Wall |
| Hardie Panel Siding w/Hardie Trim  | \$4.00     | Sq Ft Wall |
| Spruce/Pine Lap Siding w/Rough Sawn Trim (Stain/Sealant will Increase cost)      | \$5.00     | Sq Ft Wall |
| Cedar Lap Siding w/Rough Sawn Trim (Stain/Sealant will Increase cost)            | \$8.50     | Sq Ft Wall |
| Spruce/Pine Half Log siding w/Rough Sawn Trim (Stain/Sealant will Increase cost) | \$5.75     | Sq Ft Wall |
| 2x4 exterior wall framing Downgrade  | (\$8.00)   | Ln Ft      |
| <b>Windows</b>   |            |            |
| 3030 Single Hung / Insulated / Vinyl / Energy-Rated                              | \$329.00   | Ea         |
| 3040 Single Hung / Insulated / Vinyl / Energy-Rated                              | \$427.00   | Ea         |
| 6040 Double Hung / Insulated / Vinyl / Energy-Rated                              | \$894.00   | Ea         |
| 9040 Triple Hung / Insulated / Vinyl / Energy-Rated                              | \$1,375.00 | Ea         |
| 3020 Slider / Insulated / Obscure Glass (bathroom) / Vinyl / Energy-Rated        | \$303.00   | Ea         |
| 3020 Slider / Insulated / Vinyl / Energy-Rated                                   | \$303.00   | Ea         |
| 3020 Fixed - Non operable / Insulated / Vinyl / Energy-Rated                     | \$303.00   | Ea         |
| 6020 Fixed - Non operable / Insulated / Vinyl / Energy-Rated                     | \$413.00   | Ea         |
| Clerestory Trapezoid - Smaller of 2 shown  | \$826.00   | Ea         |
| Clerestory Trapezoid - Larger of 2 shown   | \$1,029.00 | Ea         |
| <b>Interior</b>  |            |            |
| Additional Interior walls - unfinished 2x4                                       | \$10.00    | Ln Ft      |
| Additional interior rough openings   | \$35.00    | Ea         |
| Interior first story wood subfloor downgrade (for concrete slab foundation)      | (\$6.00)   | Sq Ft      |



# TUFF SHED®

The Cabin Shell Series

# Cabin Shells

## Popular Options

Customers looking to add personal touches to their TUFF SHED cabin shells can choose from a variety of upgrades. Ask your local TUFF SHED sales professional about popular cabin shell upgrades in your area.



### Dormers

On cabin shells with second floor space, dormers add curb appeal, usable space and natural light. Choose from flat roof dormers (top) or gable roof dormers (bottom).



### Interior Wall Framing

TUFF SHED cabin shells come with a set amount of unfinished interior wall framing, which varies by building model. Customers wanting to change the interior floor plan can add or subtract interior wall framing.

### Paint / Stain

Add color and protection by having TUFF SHED paint or stain the exterior of your building. Published paint prices are for two coats of quality Glidden Professional latex paint on our standard LP SmartSide™ Siding and Trim Boards. See sales person for quote on alternative coatings and sidings.



### Siding

TUFF SHED cabin shells come standard with LP SmartSide™ vertical groove siding and trim boards. Change the look of any cabin shell with a variety of siding options, such as cedar lap siding, split log, cement board, board and batten, etc. Published paint prices on cabin shells assume TUFF SHED standard siding. See sales person for details on siding and corresponding paint/stain options.



Cedar Lap Siding



Split Log Siding



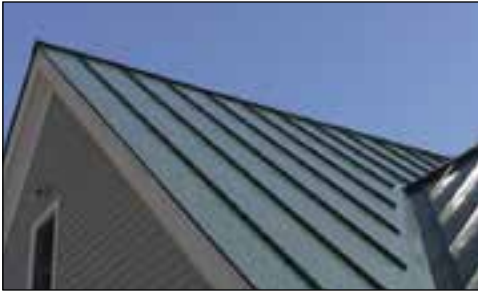

### Roof Type, Pitch and Overhangs

TUFF SHED cabin shells come standard with Owens Corning dimensional shingles. Popular roofing upgrades on cabin shells include standing seam metal roof (shown here), steeper roof pitches, or custom overhangs (eaves).



9-lite door



4-lite door



Fan light door



15-lite door

### Entry Door Upgrades

Make a statement with entry doors, upgrading the standard steel six panel door to a custom configuration like any of the doors shown here.



Uncovered Deck

Covered Deck

### Deck/Porch

#### Roof/Railing/Stairs

Create outdoor living space by adding uncovered deck, or covered porch roof to your TUFF SHED cabin shell.



Single Hung

Trapezoid

Small Transom

### Windows

TUFF SHED cabin shells include insulated vinyl windows as shown per model layout. Other window sizes and designs can be easily added.



### Bump Out

Add interior and exterior dimension to a cabin shell with a small bump out. These are typically designed to incorporate windows or doors.

# Cabin Shells Foundation Types

A reinforced concrete foundation is required for all TUFF SHED Cabin Shell Series buildings. Foundations are sold separately. Here are several types of reinforced concrete foundations. Local building codes may vary and require a specific foundation type.

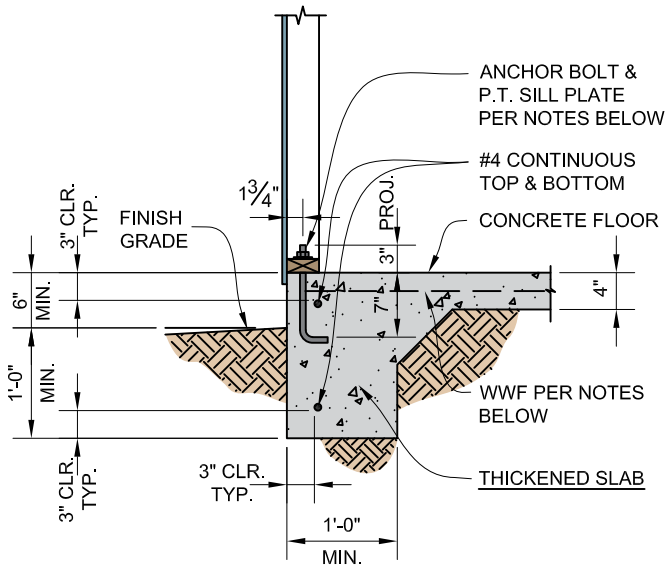

Monolithic Foundation

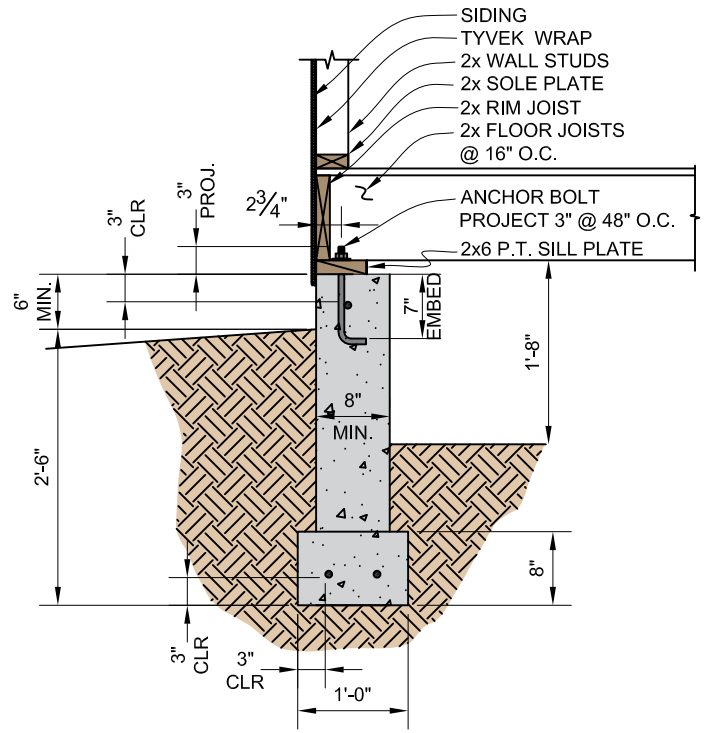

Spread-Footing Foundation

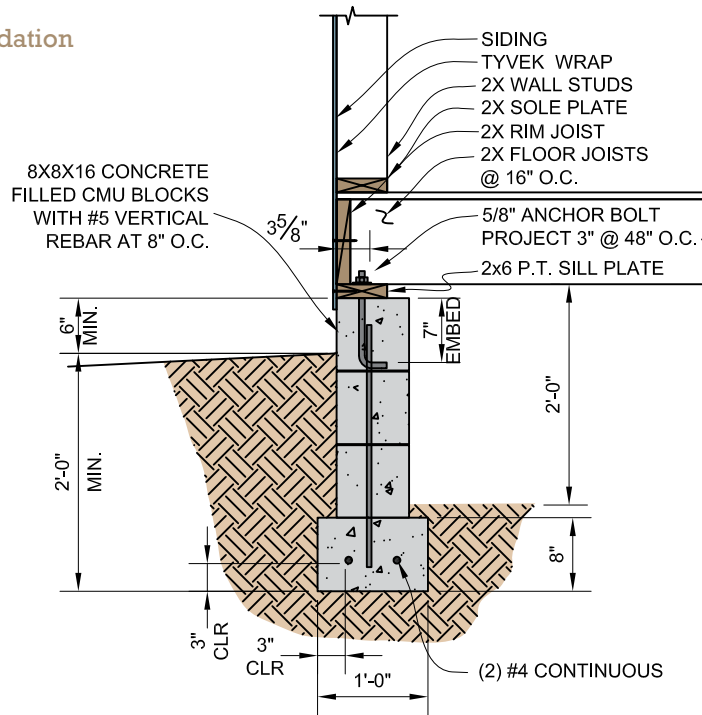

Concrete Filled CMU Foundation

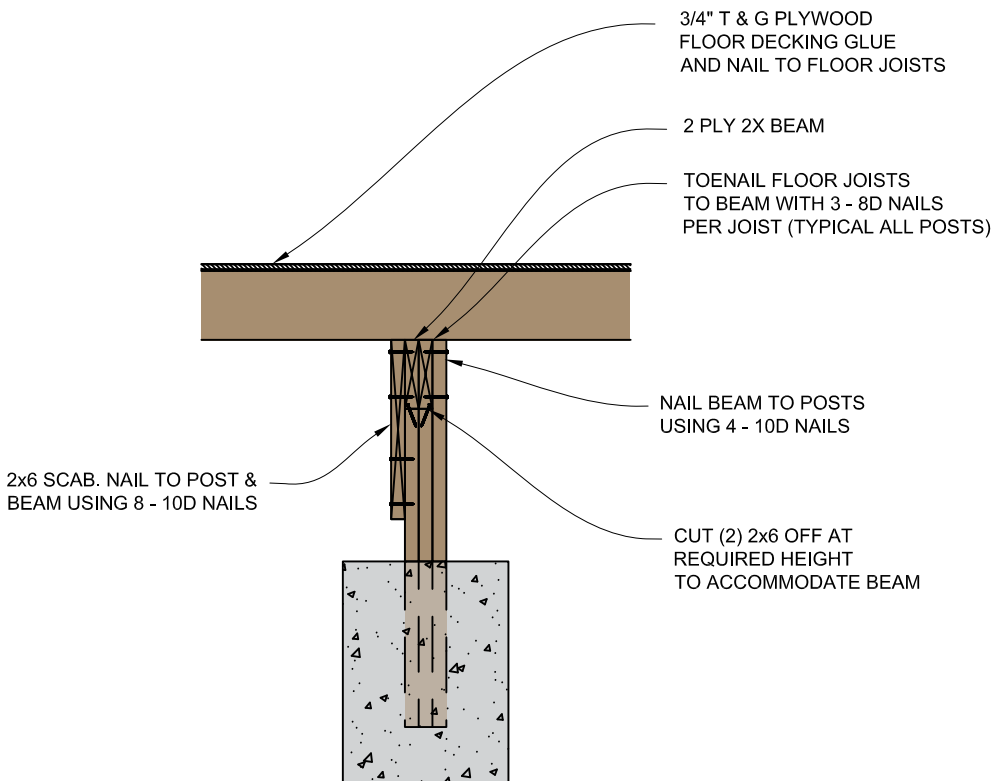

Pier and Beam Foundation

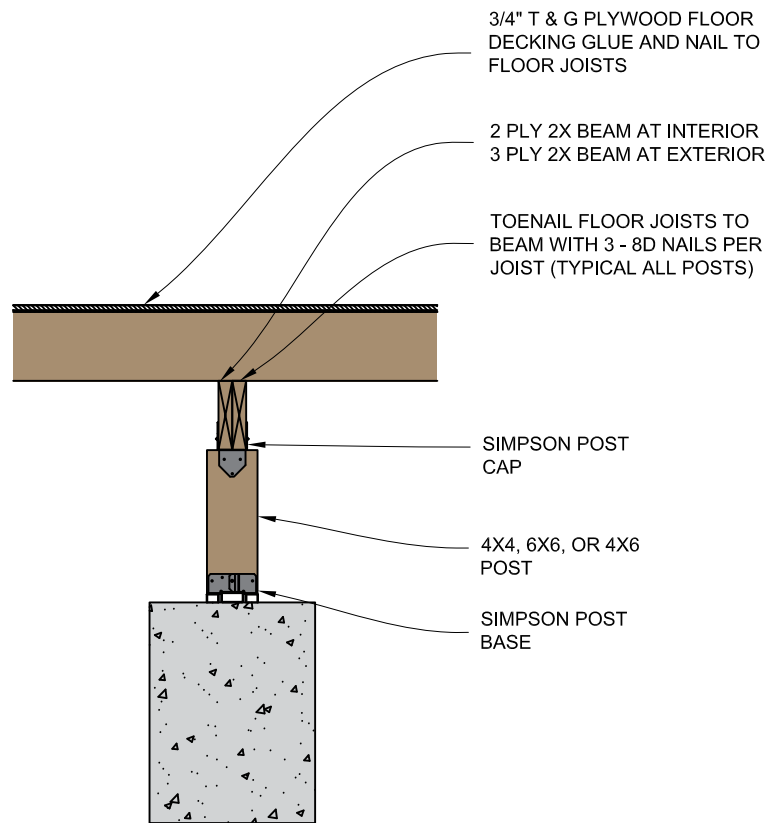

Pier and Beam Foundation



# Cabin Shells

## Garages and Storage Buildings

Add a matching TUFF SHED structure for your vehicles and gear.

